

# BSL07/13/14/20

## Installation Instructions

Self-Testing Emergency LED Driver

# bodine



### **! IMPORTANT SAFEGUARDS !**

**WHEN USING ELECTRICAL EQUIPMENT, BASIC SAFETY PRECAUTIONS SHOULD ALWAYS BE FOLLOWED, INCLUDING THE FOLLOWING:**

## **READ AND FOLLOW ALL SAFETY INSTRUCTIONS**

1. This product is for use with an emergency LED lighting load in compliance with NFPA-101 and NEC 700.12. See table on Page 2 for product ratings.
2. Make sure all connections are in accordance with the National Electrical Code or Canadian Electrical Code and any local regulations.
3. To reduce the risk of electric shock, disconnect both normal and emergency power supplies before servicing. Follow the instructions in the OPERATIONS section to disable the output of this LED driver.
4. This emergency driver is intended to be mounted on or enclosed within a luminaire and is suitable for both factory or field installation. Emergency driver with separate battery is intended to be enclosed within a luminaire and is suitable for both factory or field installation. For field installation, please see "Step #1 Determine Suitability" on Page 2 of these instructions.
5. This product is suitable for use in damp locations product is also suitable for installation in sealed and gasketed fixtures. Product is not suitable for heated air outlets, outdoors, wet, or hazardous locations. Maximum allowable case temp is 65°C. See the unit label for Tcase measurement location. See Page 2 for rated ambient temperature ranges.
6. An unswitched AC power source is required (120-277 VAC, 50/60 Hz).
7. Do not install near gas or electric heaters.
8. Do not attempt to service the battery. A sealed, no-maintenance battery is used that is not field replaceable. Contact the manufacturer for information on service.
9. The use of accessory equipment not recommended by the manufacturer may cause an unsafe condition.
10. Do not use this product for other than intended use.
11. Installation and servicing should be performed by qualified personnel.
12. Equipment should be mounted in locations and at heights where it will not be subjected to tampering by unauthorized personnel.
13. For Canadian application the output terminals should be in compliance with the accessibility requirement of the Canadian Electric Code.
14. This device complies with part 15 of the FCC Rules. Operation is subject to the following two conditions: (1) this device may not cause harmful interference, and (2) this device must accept any interference that may cause undesired operation.
15. This product must be grounded. See the wiring diagrams for details.

## **SAVE THESE INSTRUCTIONS**

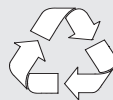

Li - ion

THIS PRODUCT CONTAINS A RECHARGEABLE LITHIUM-ION BATTERY.  
THE BATTERY MUST BE RECYCLED OR DISPOSED OF PROPERLY.

03/24/21

Bodine © 2020 Signify Holding. All rights reserved.

236 Mt. Pleasant Rd. • Collierville, TN USA 38017-2752 • Tech Support 888-263-4638 • Fax 901-853-5009 • www.bodine.com  
442295482661

# INSTALLATION

Make sure the necessary branch circuit wiring is available. An unswitched source of power is required. The emergency driver must be fed from the same branch circuit as the AC driver.

Order Code	Product 12NC	Output Rating	Output Voltage	Output Power *	Operating Time	Rated Temperature	Conduit
BSL20B2UEK55C1I1	913702487901	Class 2	20-54 VDC	20W	90 min	0C-55C	Conduit
BSL20B2UEK55L1I1	913702488001	Class 2	20-54 VDC	20W	90 min	0C-55C	Non-Conduit
BSL20B2UCK55C1I1	913702488101	Class 1	54-200 VDC	20W	90 min	0C-55C	Conduit
BSL20B2UCK55L1I1	913702488201	Class 1	54-200 VDC	20W	90 min	0C-55C	Non-Conduit
BSL14B2UAK55C1I1	913702487101	Class 2	15-54 VDC	14W	90 min	0C-55C	Conduit
BSL14B2UAK55L1I1	913702487301	Class 2	15-54 VDC	14W	90 min	0C-55C	Non-Conduit
BSL14B2UAK55C12HI1	913702487001	Class 2	15-54 VDC	14W	120 min	0C-55C	Conduit
BSL14B2UAK55L12HI1	913702487201	Class 2	15-54 VDC	14W	120 min	0C-55C	Non-Conduit
BSL14B2UCK55C12HI1	913702487401	Class 1	54-200 VDC	14W	120 min	0C-55C	Conduit
BSL14B2UCK55L12HI1	913702487601	Class 1	54-200 VDC	14W	120 min	0C-55C	Non-Conduit
BSL20B6UEK55SBI1	913702488401	Class 2	20-54 VDC	20W	90 min	0C-55C	Non-Conduit
BSL14B6UAK55SBI1	913702487801	Class 2	15-54 VDC	14W	90 min	0C-55C	Non-Conduit
BSL07B2UAK55L14HI1	913702489101	Class 2	15-54 VDC	7W	240 min	0C-55C	Non-Conduit
BSL20B6UEG55SBI1	913702488301	Class 2	20-54 VDC	20W	90 min	-20-55C	Non-Conduit
BSL14B2UCK55C1I1	913702487501	Class 1	54-200 VDC	14W	90 min	0C-55C	Conduit
BSL14B2UCK55L1I1	913702487701	Class 1	54-200 VDC	14W	90 min	0C-55C	Non-Conduit
BSL13B2UAG55L1I1	913702489001	Class 2	15-54 VDC	13W	90 min	-20-55C	Non-Conduit
BSL13B6UAG55SBI1	913702486901	Class 2	15-54 VDC	13W	90 min	-20-55C	Non-Conduit

\* Initial output power after one minute into discharge.

**Installation of this emergency LED driver will vary based on the luminaire type, however, generally follow these steps:**

## STEP #1 DETERMINE SUITABILITY

This product is suitable for field installation with suitable LED loads including LED luminaires, DC voltage driven LED replacements for fluorescent lamps and others. There are four (4) checks to determine if your luminaire is eligible for field installation.

1. Ensure the LED load's rated power is greater than or equal to the power output of this emergency LED driver. This is to ensure that this emergency product will not produce more power than the LED load can handle, thus ensuring that the LED load will not be damaged when the system is in the emergency mode.
2. Verify that the forward voltage of the luminaire's LED array is within the limits of this emergency LED driver. The forward voltage of the LED array is commonly designated as Vf and should be found on the luminaire markings, in the luminaire specifications, or imprinted directly on the LED arrays. If multiple LED arrays are to be driven, verify that the total forward voltage is within the limits of this product. Using a voltage meter, it may be possible to directly measure the voltage across the LED arrays when operating from the AC driver.
3. Ensure the output current of the AC LED driver does not exceed 5.0 Amps for Class 2 emergency product and 3.0 Amps for Class 1 emergency product (see table above).
4. Ensure there will be sufficient light output in the end application. Estimate the egress lighting illumination levels by doing the following:
  - a. Find the efficacy of the LED load. This can be given by the luminaire manufacture. This number will be given in lumens per watt (lm/w). It is the installer's responsibility to validate the luminaire manufacturer's efficacy data. This can be accomplished by direct measurement, by review of independent 3rd party test data (UL, ETL, etc.), accessing a public database of 3rd party data (such as Design Lights Consortium, www.designlights.org), or other comparable means.
  - b. Lumens can be calculated by multiplying the output power of the emergency LED driver (see table above) by the efficacy of the luminaire. In many cases the actual lumen output in emergency mode will be greater than the results of this calculation, however it will provide a good estimate for beginning the lighting design of the system.

**Lumens In Emergency Mode = Lumens per Watt of Fixture \* Output Power of Chosen Product**

$$\underline{\hspace{2cm}} \text{ (Lumens) } = \underline{\hspace{2cm}} \text{ (lm/W) } \times \underline{\hspace{2cm}} \text{ (W)}$$

- c. Using the results of this calculation and industry standard lighting design tools, calculate the anticipated illumination levels in the path of egress.

NOTE: This product has been designed to reliably interface with a wide selection of LED loads and is electrically compatible with every simple LED array that meets criteria 1 and 2 above. However, compatibility cannot be guaranteed with all current and future LED systems. Compatibility testing of the end-use system is recommended. Please contact the factory for more information.

NOTE: After installation, it will be necessary to measure the egress lighting illumination levels to ensure they comply with national, state, and local code requirements.

## STEP #2 ► INSTALLING THE EMERGENCY DRIVER

- > Disconnect AC power from the LED luminaire.
- > Mount the emergency LED driver by the mounting tabs using the supplied screws. The luminaire's installation instructions may provide guidance on the recommended mounting location.
- > Mounting Height: Many factors influence emergency illumination levels, such as the lamp load selected, luminaire design, and environmental factors therefore end use verification is necessary. For field installations, when the attached luminaire is mounted at heights greater than 7.17ft (2.2m), the level of illumination must be measured in the end application to ensure the requirements of NFPA 101 and local codes are satisfied.
- > Remote Mounting: The emergency LED driver may be remote mounted from the luminaire if installed in accordance with the NEC. If used in conjunction with an AC driver the allowed distance is up to half the distance the AC driver manufacturer recommends remote mounting the AC driver from the LED load. If used without an AC driver, and remote mounting more than 5 feet from the luminaire, please consult the factory to determine the necessary wire gauge. CAUTION: Remote mounting can result in reduced power output.

## STEP #3 ► INSTALLING THE ILLUMINATED TEST SWITCH

- > Mount the supplied Illuminated test switch in a location that is visible and accessible by maintenance personnel. The test switch mounts through a ½" hole which may need to be made in the luminaire or could come pre-punched by the luminaire supplier.
- > Connect the test switch by connecting it to the unit test switch cable.
- > If connected correctly, the indicator light should be ON when AC power is supplied to the fixture indicating that the unit is charging. After installing, mark with the "PUSH TO TEST" and "CHARGING INDICATOR LIGHT" labels.

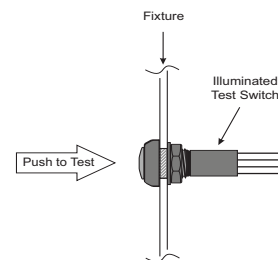

## STEP #4 ► WIRING THE EMERGENCY DRIVER

- > Select the appropriate wiring diagram to connect the emergency driver to the AC driver and LED load. Make sure all connections are in accordance with the National Electrical Code and any local regulations.
- > After installation is complete, supply AC power to the emergency driver.
- > At this point, power should be connected to both the AC driver and the emergency driver, and the Charging Indicator Light should illuminate indicating the battery is charging.
- > A short-term discharge test may be conducted after the emergency driver has been charged for one hour. Charge for 24 hours before conducting a long-term discharge test. Refer to OPERATION.
- > In a readily visible location, attach the label "CAUTION - This Unit Has More Than One Power Connection Point. To Reduce The Risk Of Electric Shock, Disconnect Both The Branch Circuit-Breakers Or Fuses And Emergency Power Supplies Before Servicing."

## OPERATION

Applying AC power to the unit activates its emergency function and the charger circuit, and supplies power to the control/monitor circuit and charging indicator light. When AC power fails, the emergency driver automatically switches to emergency mode, keeping the LED load illuminated at a reduced lumen output for a minimum of 90 minutes (or longer for 2 hr and 4 hr emergency run-time products). When AC power is restored, the emergency driver returns to charging mode.

This unit contains a control/monitor circuit that automatically performs a 30-second discharge test once a month and a full 90-minute discharge test once a year. During routine testing, the emergency driver simulates an AC power failure causing the unit to automatically switch to emergency mode. The unit will monitor the operation of the LED load, battery voltage, LED load connections and emergency duration. At the end of this test, if the emergency system functions properly, the unit will return to normal operation. Should the unit detect any problems, the indicator light will flash per failure condition (see Troubleshooting guide) until the condition has been corrected and the unit passes the next test.

**To reset a failure indication**, turn off AC power to the emergency driver for a minimum of 10 seconds or briefly push the test switch. If the condition has not been corrected by the next scheduled test, the unit will once again detect the failure and signal the failure indicator.

**To perform a manual self-diagnostic test**, push and hold the test switch for a minimum of 5 seconds while AC power is applied. Once the test switch is released the emergency driver will perform a 30 second diagnostic test. During this test, the unit will monitor the operation of the LED load, battery voltage, and LED load connections. If the emergency system functions properly, the unit will return to normal mode. Should the unit detect any problems, the indicator light will flash per failure condition (see Troubleshooting guide) until the condition has been corrected and the unit passes the next test.

**To deactivate the unit for storage or shipping**, press and hold the test button while the unit is in emergency mode until the LED load is turned off. Emergency mode will activate when unswitched AC power is turned off.

## MAINTENANCE

This self testing emergency driver automatically performs required routine testing. Results are reported to maintenance personnel via the indicator light.

**Note:** Maintenance personnel should periodically check the indicator light per Life Safety Code requirements (NFPA 101). If the indicator light is flashing, follow steps in the following Troubleshooting Guide.

## TROUBLESHOOTING GUIDE

If the unit has encountered a problem after installation, then it will flash the error code with the indicator light. Count the number of times the indicator is OFF to read the number of flashes. Then use the troubleshooting steps to solve the issue.

INDICATOR LIGHT STATE	ERROR	CORRECTIVE ACTION
0x Flashes Light On Steady	None	No Action. The Unit is Operating Correctly.
2x Flashes	Battery	Indicates that a self-test/self-diagnostic test did not meet full duration. 1. Charge the unit for the rated recharge time and perform a manual self-diagnostic test. 2. If error is still present then the battery is past end of life and should be replaced.
3x Flashes	Charging	1. Check input AC mains wiring of Unswitched Hot, Neutral, and Ground. 2. Verify Voltage and Frequency are stable and match the product's input ratings on the label.
4x Flashes	Commissioning	During a self-test/self-diagnostic test, the unit detected the LED load has changed of more than 25% from the initial commissioned value. 1. Replace the LED Load and perform a manual self-diagnostic test. 2. If error is still present then recalibrate the commission value by deactivating the unit. Apply AC mains to activate unit and it will recommission itself after one hour.
5x Flashes	Temperature	Product temperature is beyond its rated temperature range. 1. Ensure unit is within the rated temperature range stated on the product label. 2. Confirm by measuring at the Tc point on the product label.
Continuous Flashing	LED Load	Indicates a problem with the connected emergency LED load. 1. Check output wiring to the LED Load and verify polarity is correct. 2. Check for Open or Short circuit on the output connections. 3. Check Vf is within the rated output voltage range in emergency mode. 4. Ensure LED load is operational and specified for unit.

**NOTE:** For short-term testing of the emergency function, the battery must be charged for at least one hour. The emergency driver must be charged for at least 24 hours before conducting a long-term test.

# WIRING DIAGRAMS

## EMERGENCY DRIVER AND AC DRIVER MUST BE FED FROM THE SAME BRANCH CIRCUIT

TYPICAL SCHEMATICS ONLY. CONSULT THE FACTORY FOR OTHER WIRING DIAGRAMS.

### For Class 1 Emergency Driver Separate Battery

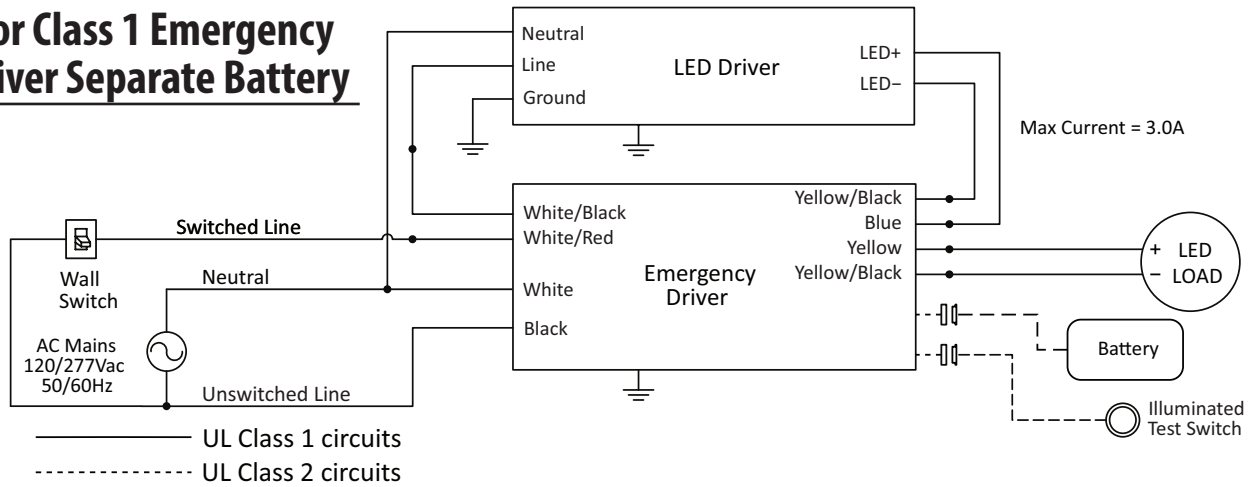

### For Class 1 Emergency Driver Internal Battery

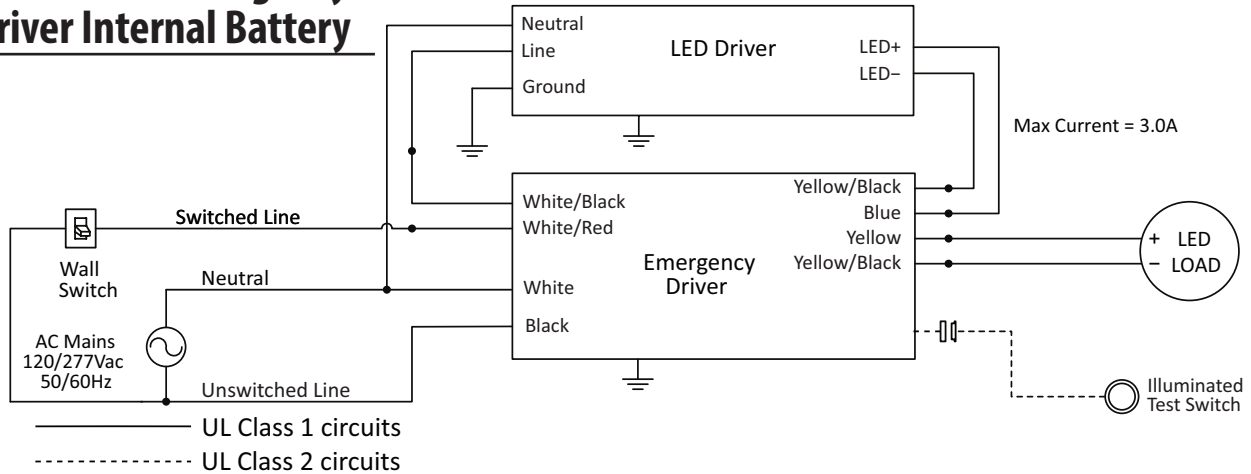

**NOTE:** For short-term testing of the emergency function, the battery must be charged for at least one hour. The emergency driver must be charged for at least 24 hours before conducting a long-term test.

# WIRING DIAGRAMS

## EMERGENCY DRIVER AND AC DRIVER MUST BE FED FROM THE SAME BRANCH CIRCUIT

TYPICAL SCHEMATICS ONLY. CONSULT THE FACTORY FOR OTHER WIRING DIAGRAMS.

### For Class 2 Emergency Driver Separate Battery

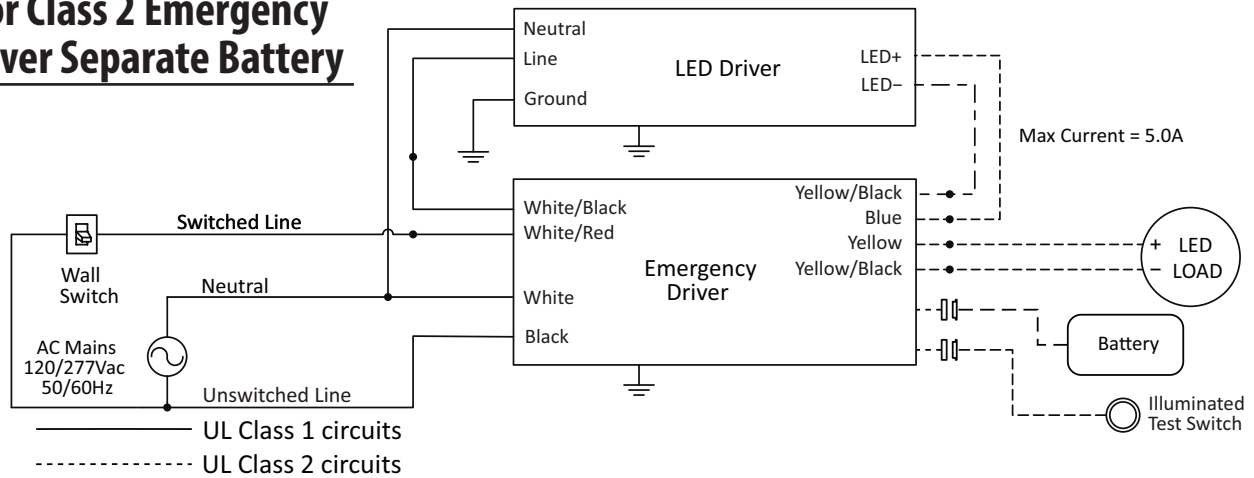

### For Class 2 Emergency Driver Internal Battery

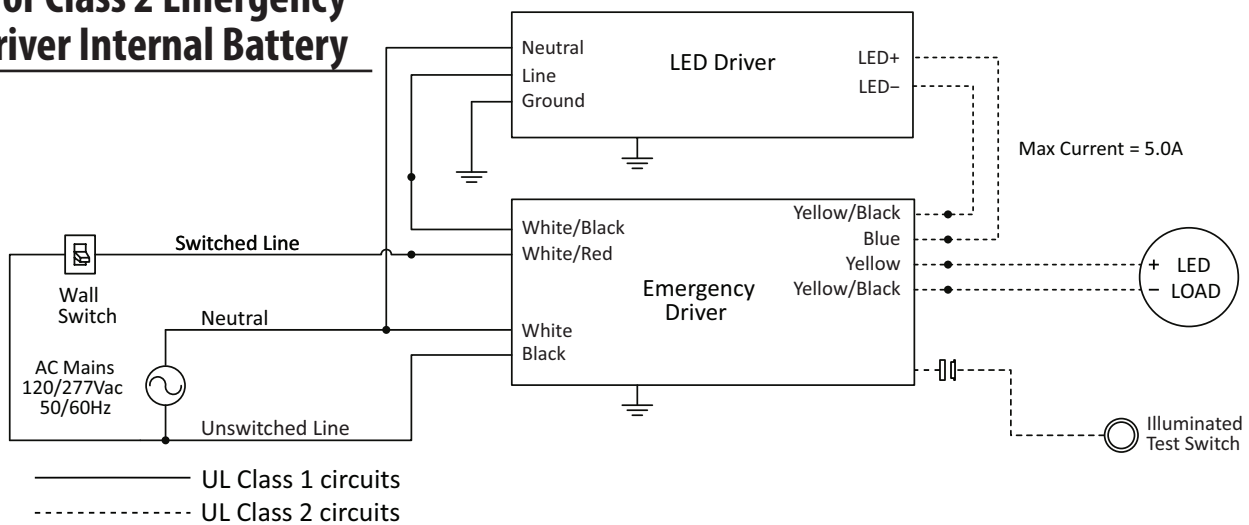

**NOTE:** For short-term testing of the emergency function, the battery must be charged for at least one hour. The emergency driver must be charged for at least 24 hours before conducting a long-term test.