



The Advance Xitanium range of phase-cut dimming LED drivers is perfectly suited for commercial fittings in downlight and track lighting applications. These models offer the flexibility of precise output of drive currents from selectable settings and are compatible with a variety of electronic low voltage dimmers to deliver reliably smooth dimming performance. The drivers are offered in a compact form factor suitable for use in elegantly unobtrusive fixture designs. Rated for long life with efficient performance, these drivers are excellent design choices for LED downlight fixtures and offer the benefits of long-lasting energy savings with low maintenance costs.

Specifications

Input Voltage (Vrms)	Output Power (W)	Output Voltage (V)	Output Current (A)	Efficiency@ Max. Load and 70°C Case	Max. Case Temp. (°C)	Input Current (Arms)	Max. Input Power (W)	THD @ Max. Load	Power Factor @ Max. Load	Surge Protection Common/ Diff (KV)	Envir. Protection Rating	Driver Type
120	42	26-52 Class 2 Output	0.5-0.8	88	Life - 75°C Max. - 85°C	0.4	47	<15%	>0.95	2.5	UL Damp & Dry	Constant Current
277				87		0.19		<20%				

Enclosure

P can	In. (mm)
Case Length (L2)	3.74 (95)
Case Width (W)	2.75 (70)
Case Height (H)	1.26 (32)
Mounting Length (M)	3.35 (85)

Wiring Diagram

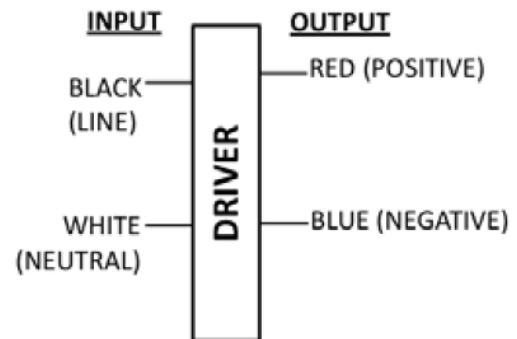

Input and output use lead wires.

Lead-wires are 18AWG 105C/600V stranded copper.

Standard lead length is 150mm (±10mm) on all wires outside the can.

All wires have tinned ends.

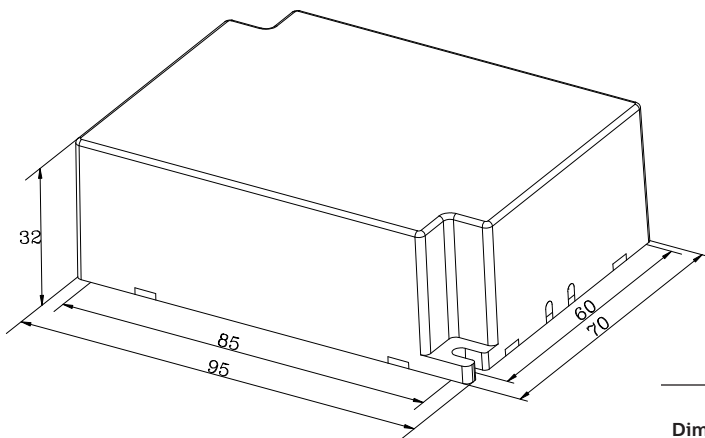

Warning

- Install in accordance with national and local electrical codes.
- The field-wiring leads or push-in terminals shall be fully enclosed.

Dimming	Dimming Range	Minimum Output Current (A)	Other Comments
LE + TE Leading Edge & Trailing Edge	3.5% ~ 100%	0.0175	Only @ 120V



RoHS
COMPLIANT

Xitanium XI042C080V052RNP1

42W 0.5–0.8A 52V LE+TE INT

Features

- 50,000+ hour lifetime¹
- UL Class 2 output with adjustable drive current
- Leading edge / Trailing edge dimming
- Compact form factor

Benefits

- Enables easy design-in with excellent thermal performance
- Enables simple, fast, flexible application-specific configurations
- Enables light levels suited for the application
- Enables design of low-profile fixtures

Application

- Indoor downlight and track applications
- Retail
- Hospitality

Electrical Specifications

All the specifications are typical and at 25°C Tcase unless specified otherwise.

Product Data

Order Information	
Full Product Code	XI042C080V052RNP1M (Mid-Pack, 20pcs/Box), 12NC: 929000795413
Line Frequency	50/60Hz
Min. Mains Voltage Operational	108 Vac
Max. Mains Voltage Operational	305 Vac
Output Information	
Maximum Open Circuit Voltage	<60Vdc
Output Current Ripple	30% max. @ max. Iout
Output Current Tolerance (within full output operating range)	500mA: (-8% / +5%) 600mA: (-8% / +5%) 700mA: (-8% / +5%) 800mA: (-8% / +5%) Output Current variation includes effects of line & load regulation, temperature variation and component tolerances
Protections	Short Circuit, Open Circuit Protection for LED + and LED – and Temperature Foldback
Features	
Dimming	LE + TE dimming
AOC (adjustable output current)	500mA to 800mA via DIP switches (refer to figure & notes in the Electrical Specification section)
Environment & Approbation	
Operating Ambient Temp. Range	-20°C to +50°C
Max. Case Temperature (Tcase)	Tcase Life: 75°C, Max. 85°C
Agency Approbations	UL8750, UL991, Class P (UL, cUL)
Electromagnetic Compliance	FCC Title 47 Part 15 Class A
Audible Noise	<24dB Class A
Weight	0.7218 Lbs / 0.327 kgs

1. Advance Xitanium LED drivers are manufactured to engineering standards correlating to a designed and average life expectancy of 50,000 hours of operation at maximum rated case temperature. Minimum 90% survivals based on MTTF modeling.

Xitanium XI042C080V052RNP1

42W 0.5-0.8A 52V LE+TE INT

Electrical Specifications

All the specifications are typical and at 25°C Tcase unless specified otherwise.

LE + TE Dimming

Minimum Dim Level: 3.5% of Iout (minimum 17.5mA)

Approved Dimmer List

Manufacturer	Manufacturer Part Number	Type of Dimmer	Min. Number of Drivers per Dimmer	Max. Number of Drivers per Dimmer
Lutron	DV-600P	Leading Edge	1	Dimmers can be loaded up to 80% of their max. power rating
	DVELV-303P	Trailing Edge		
	NTELV-600	Trailing Edge		
	MAELV-600	Trailing Edge		
	DVLV-600P	Leading Edge		
	SELV-300P	Leading Edge		
	NFTU-5A	Leading Edge		
	CTCL-153P	Leading Edge		
	GL-600H	Leading Edge		
	S-600P	Leading Edge		
	PHPM	277V		

Xitanium XI042C080V052RNP1

42W 0.5-0.8A 52V LE+TE INT

Electrical Specifications

All the specifications are typical and at 25°C Tcase unless specified otherwise.

AOC (Adjustable Output Current) Settings:

The output current of the driver can be adjusted using the two dip switches provided on the bottom of the driver.

The below picture shows the switch positions required to set the current to different levels.

Switch 1	Switch 2	Drive Current
OFF	OFF	500mA
OFF	ON	600mA
ON	OFF	700mA
ON	ON	800mA (factory default)

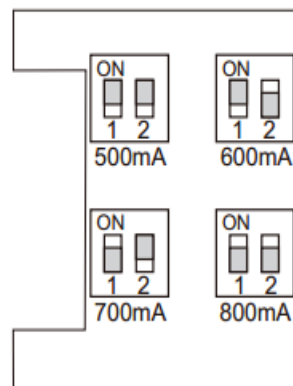

Notes

The driver will be shipped out of factory with a default of 800mA.

Xitanium XI042C080V052RNP1

42W 0.5-0.8A 52V LE+TE INT

Electrical Specifications

All the specifications are typical and at 25°C Tcase unless specified otherwise.

Output Current Vs. Driver Case Temperature

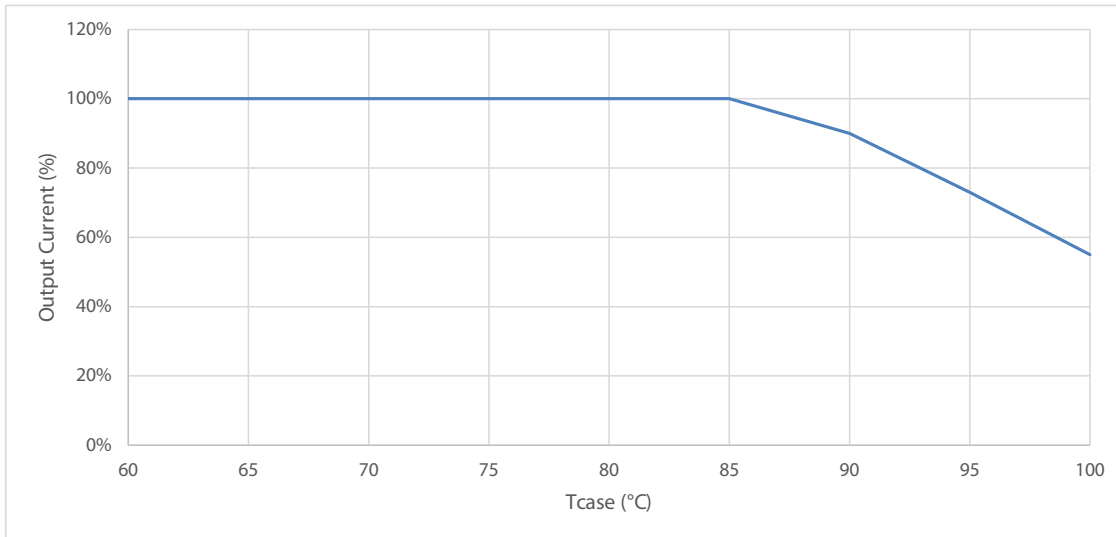

Note

There is $\pm 5^\circ\text{C}$ tolerance on the driver case temperature.

Driver Lifetime Vs. Driver Case Temperature

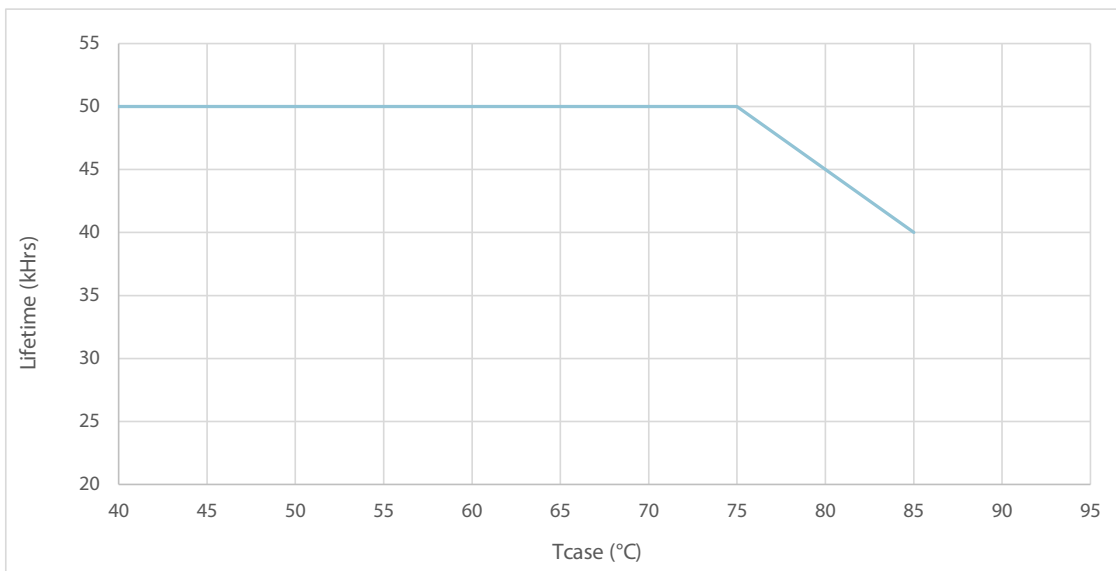

Xitanium XI042C080V052RNP1

42W 0.5-0.8A 52V LE+TE INT

Performance Characteristics

Based on measurements on a typical sample at 75°C case. The accuracy of the measurements is within the tolerance of the measurement instruments.

Efficiency Vs. Output Voltage at 120Vac

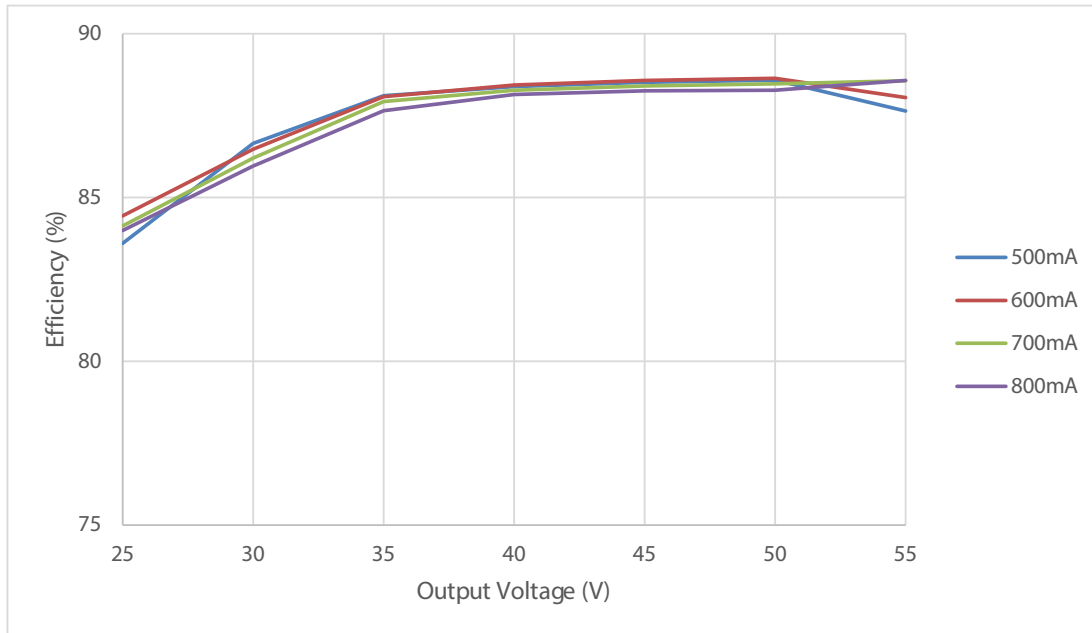

Efficiency Vs. Output Voltage at 277Vac

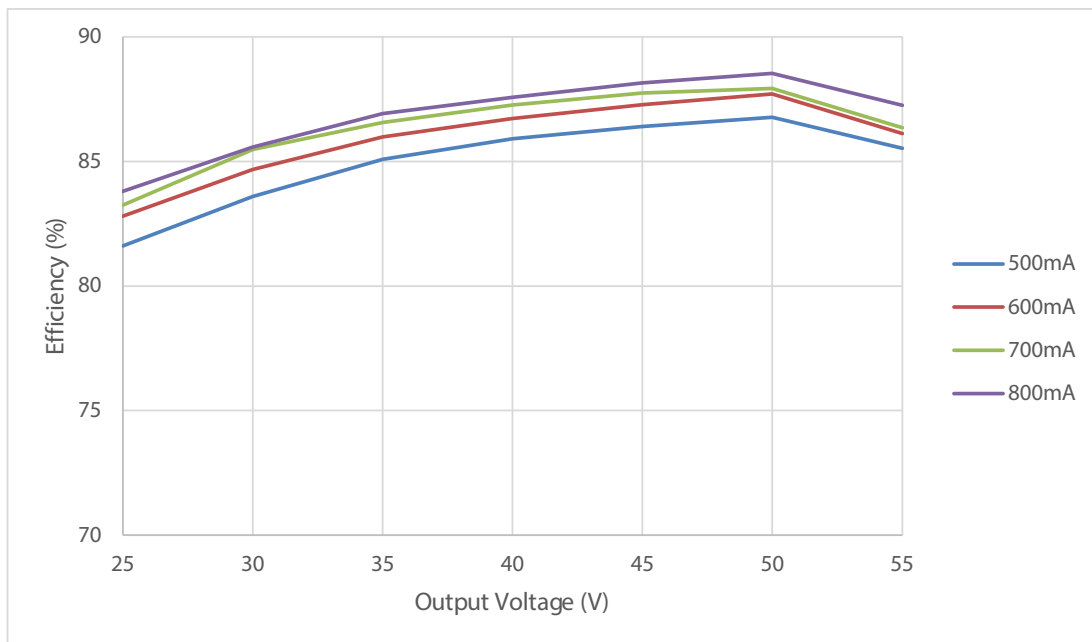

Xitanium XI042C080V052RNP1

42W 0.5-0.8A 52V LE+TE INT

Performance Characteristics

Based on measurements on a typical sample at 75°C case. The accuracy of the measurements is within the tolerance of the measurement instruments.

Power Factor Vs. Output Power at 500mA

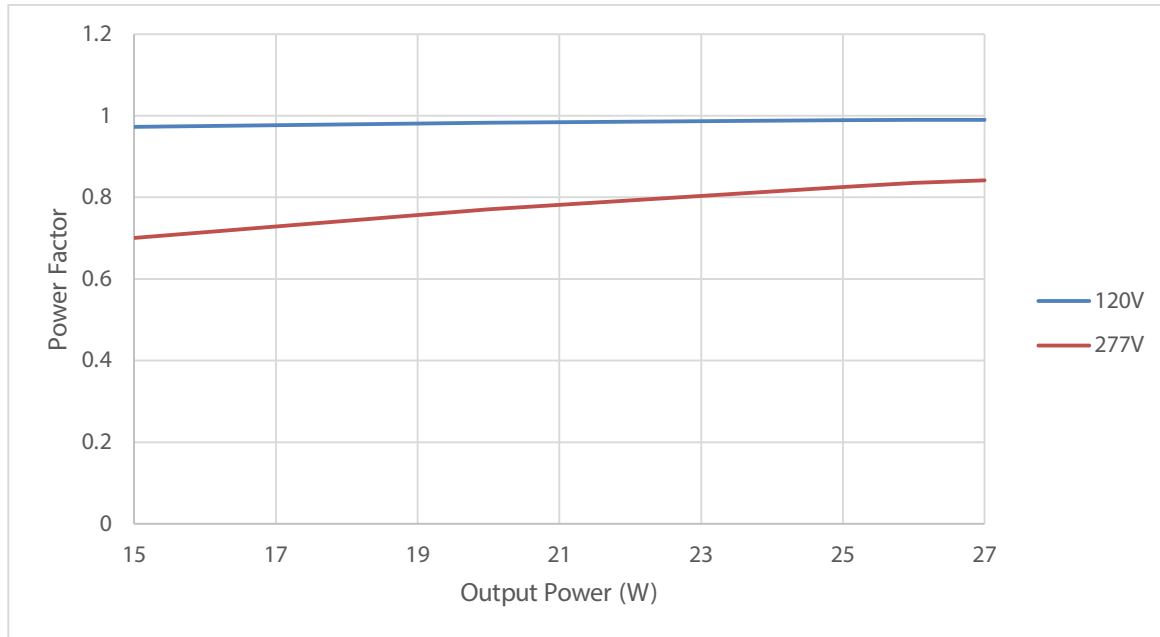

Power Factor Vs. Output Power at 800mA

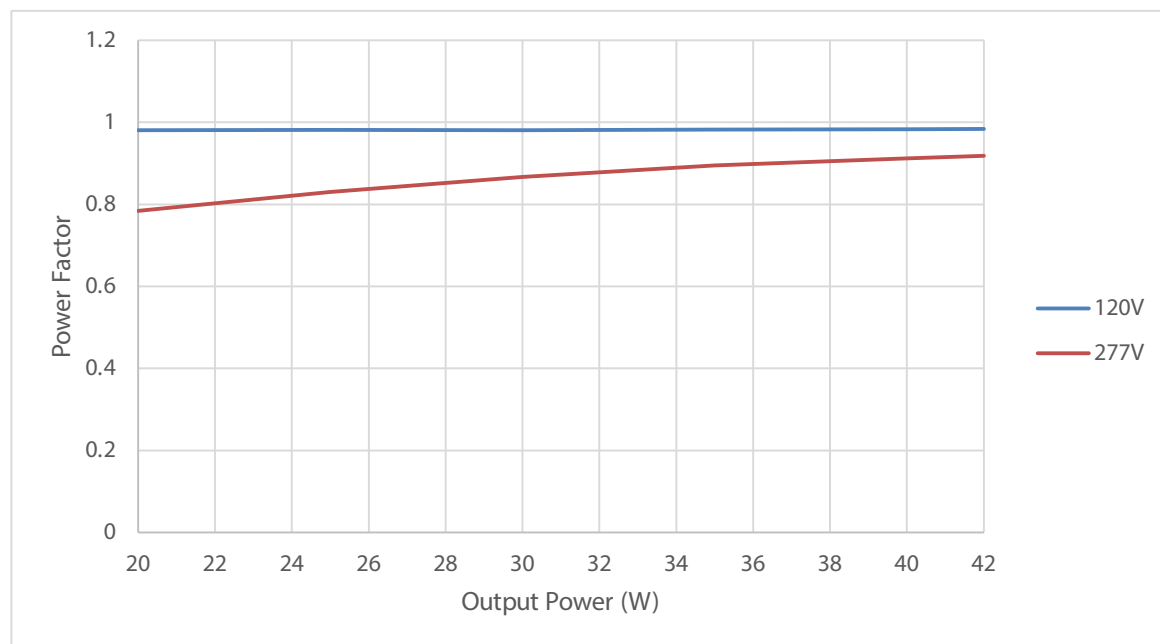

Xitanium XI042C080V052RNP1

42W 0.5-0.8A 52V LE+TE INT

Total Harmonic Distortion (THD) Vs. Output Power

Based on measurements on a typical sample at 75°C case. The accuracy of the measurements is within the tolerance of the measurement instruments.

THD Vs. Output Power at 500mA

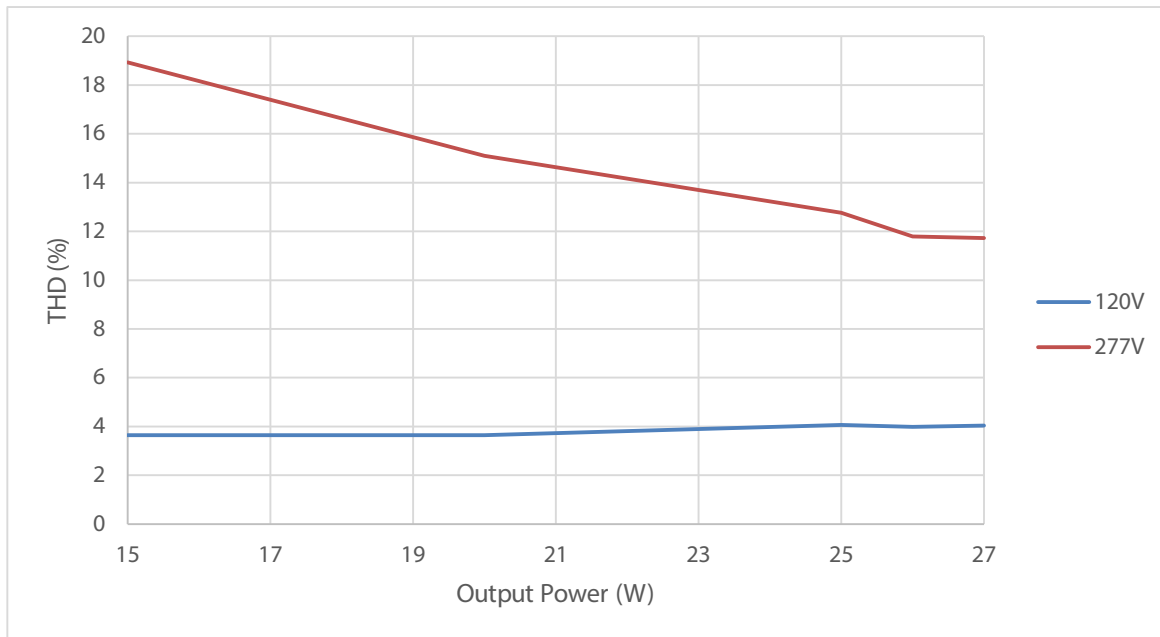

THD Vs. Output Power at 800mA

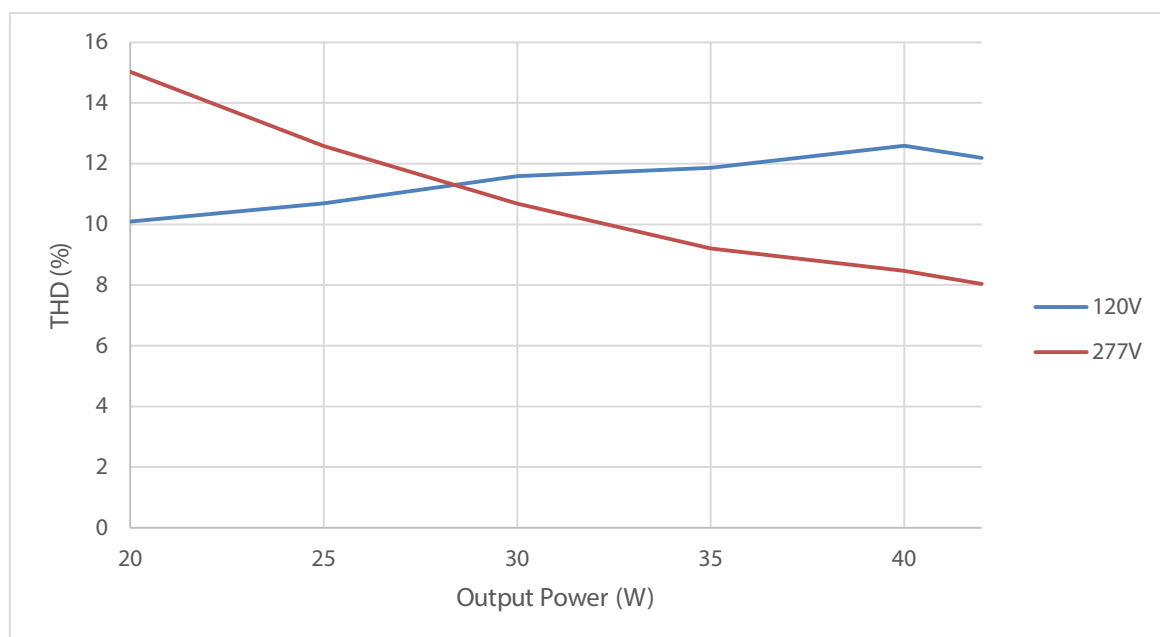

Xitanium XI042C080V052RNP1

42W 0.5-0.8A 52V LE+TE INT

Inrush Current Info

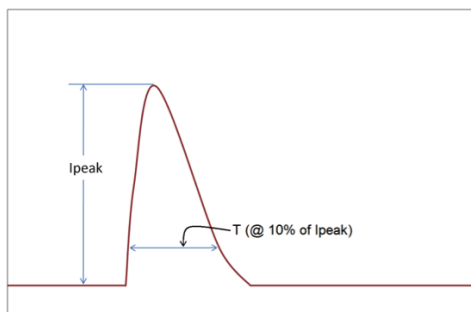

V_{in}	I_{peak}	T (@ 10% of I_{peak})
120 Vac	0.8A	810 μ s
277 Vac	2.5A	470 μ s

Inrush current is measured at peak of the corresponding line voltage, source impedance per NEMA 410.

Lightning Surge Info

ANSI Surge Type	Differential Mode (L-N)
100K Hz Ring Wave (w/t 30 Ω)	2.5kV

Isolation

Isolation	Input	Output
Input	NA	2xU+1kV
Output	2xU+1kV	NA

U=Max. working voltage

