

BSL10LST

Installation Instructions

Self-Testing Emergency LED Driver

CLASS 2 OUTPUT

bodine



! IMPORTANT SAFEGUARDS !

WHEN USING ELECTRICAL EQUIPMENT, BASIC SAFETY PRECAUTIONS SHOULD ALWAYS BE FOLLOWED, INCLUDING THE FOLLOWING:

READ AND FOLLOW ALL SAFETY INSTRUCTIONS

1. To prevent voltage from being present on output leads prior to installation, unit engage connector must be open. Do not join unit engage connector until installation is complete and AC power is supplied to the emergency driver.
2. This product is for use with an emergency LED lighting load and supplies nominally 10.0 W of power, with a voltage of 15-54 VDC in emergency mode for a minimum of 90 minutes, in compliance with NFPA-101 and NEC 700.12.
3. Make sure all connections are in accordance with the National Electrical Code or Canadian Electrical Code and any local regulations.
4. To reduce the risk of electric shock, disconnect both normal and emergency power supplies and unit engage connector of the emergency driver before servicing.
5. This emergency driver is intended to be mounted and enclosed within a luminaire and is suitable for both factory or field installation. For field installation, please see the instructions on page 2.
6. This product is suitable for use in damp locations where the ambient temperature is 0°C minimum, +55°C maximum. Product is also suitable for installation in sealed and gasketed fixtures. Product is not suitable for heated air outlets and wet or hazardous locations. Maximum allowable case temp is 63°C. See Page 4 for Tcase measurement location.
7. An unswitched AC power source is required (120-277 VAC, 50/60 Hz).
8. Do not install near gas or electric heaters.
9. Do not attempt to service the battery. A sealed, no-maintenance battery is used that is not field replaceable. Contact the manufacturer for information on service.
10. The use of accessory equipment not recommended by the manufacturer may cause an unsafe condition.
11. Do not use this product for other than intended use.
12. Servicing should be performed by qualified service personnel.
13. Equipment should be mounted in locations and at heights where it will not be subjected to tampering by unauthorized personnel.
14. For Canadian application the output terminals should be in compliance with the accessibility requirement of the Canadian Electric Code.
15. This device complies with part 15 of the FCC Rules. Operation is subject to the following two conditions: (1) this device may not cause harmful interference, and (2) this device must accept any interference that may cause undesired operation.
16. This product must be grounded. See the wiring diagrams for details.

SAVE THESE INSTRUCTIONS



Li - ion

**THIS PRODUCT CONTAINS A RECHARGEABLE LITHIUM-ION BATTERY.
THE BATTERY MUST BE RECYCLED OR DISPOSED OF PROPERLY.**

02/07/19

Bodine © 2018 Signify Holding. All rights reserved.

236 Mt. Pleasant Rd. • Collierville, TN USA 38017-2752 • Tech Support 888-263-4638 • Fax 901-853-5009 • www.bodine.com
442294606602

INSTALLATION



CAUTION: DO NOT JOIN UNIT ENGAGE CONNECTOR UNTIL INSTALLATION IS COMPLETE AND AC POWER IS SUPPLIED TO THE EMERGENCY DRIVER.

NOTE: Make sure the necessary branch circuit wiring is available. An unswitched source of power is required. The emergency driver must be fed from the same branch circuit as the AC driver.

This product is suitable for field installation with suitable LED loads including LED luminaires, DC voltage driven LED replacements for fluorescent lamps and others. There are four (4) checks to determine if your luminaire is eligible for field installation.

1. Ensure the LED load's rated power is greater than or equal to the power output of this emergency LED driver. This is to ensure that this emergency product will not produce more power than the LED load can handle, thus ensuring that the LED load will not be damaged when the system is in the emergency mode.
2. Verify that the forward voltage of the luminaire's LED array is within the limits of this emergency LED driver. The forward voltage of the LED array is commonly designated as Vf and should be found on the luminaire markings, in the luminaire specifications, or imprinted directly on the LED arrays. If multiple LED arrays are to be driven, verify that the total forward voltage is within the limits of this product. Using a voltage meter, it may be possible to directly measure the voltage across the LED arrays when operating from the AC driver.
3. Ensure the output current of the AC LED driver does not exceed 5.0 Amps. This is the current into the blue wire connector.
4. Ensure there will be sufficient light output in the end application. Estimate the egress lighting illumination levels by doing the following:
 - a. Find the efficacy of the LED load. This can be given by the luminaire manufacture. This number will be given in lumens per watt (lm/w). It is the installer's responsibility to validate the luminaire manufacturer's efficacy data. This can be accomplished by direct measurement, by review of independent 3rd party test data (UL, ETL, etc.), accessing a public database of 3rd party data (such as Design Lights Consortium, www.designlights.org), or other comparable means.
 - b. Lumens can be calculated by multiplying the output power of the emergency LED driver by the efficacy of the LED load. In many cases the actual lumen output in emergency mode will be greater than this calculation gives, however it will provide a good estimate for beginning the lighting design of the system.

Lumens In Emergency Mode = Lumens per Watt of Fixture * Output Power of Chosen Product

$$\underline{\hspace{2cm}} \text{ (Lumens) } = \underline{\hspace{2cm}} \text{ (lm/W) } * \underline{\hspace{2cm}} \text{ 6 } \text{ (W)}$$

-
-
-
- c. Using the results of this calculation and industry standard lighting design tools, calculate the anticipated illumination levels in the path of egress.

NOTE: This product has been designed to reliably interface with a wide selection of LED loads and is electrically compatible with every simple LED array that meets criteria 1 and 2 above. However, compatibility cannot be guaranteed with all current and future LED systems. Compatibility testing of the end-use system is suggested. Please contact the factory with any questions.

NOTE: After installation, it will be necessary to measure the egress lighting illumination levels to ensure it complies with national, state, and local code requirements.

Installation of this emergency LED driver will vary based on the luminaire type, however, generally follow these steps:

STEP #1 INSTALLING THE EMERGENCY DRIVER

- > Disconnect AC power from the LED luminaire.
- > Mount the emergency LED driver by the mounting tabs using the supplied screws. The luminaire's installation instructions may provide guidance on the recommended mounting location.
- > **Mounting Height:** Many factors influence emergency illumination levels, such as the lamp load selected, luminaire design, and environmental factors therefore end use verification is necessary. For field installations, when the attached luminaire is mounted at heights greater than 7.17ft (2.2m), the level of illumination must be measured in the end application to ensure the requirements of NFPA 101 and local codes are satisfied.
- > **Remote Mounting:** The emergency LED driver may be remote mounted from the luminaire it enclosed and installed in accordance with the NEC. If used in conjunction with an AC driver the allowed distance is up to half the distance the AC driver manufacturer recommends remote mounting the AC driver from the LED load. If used without an AC driver, and remote mounting more than 5 feet from the luminaire, please consult the factory to determine the necessary wire gauge.
CAUTION: Remote mounting can result in reduced power output.

STEP #2 ► INSTALLING THE 2W-ITS ON FIXTURE SURFACE

- > Mount the supplied 2W-ITS (2-wire illuminated test switch) in a location that is visible and accessible by maintenance personnel. The 2W-ITS mounts through a 1/2" hole which may need to be made in the luminaire or could come pre-punched by the luminaire supplier.
- > Wire the test switch per wiring diagrams provided on these instructions.
- > If wired correctly, the 2W-ITS indicator light should be ON when AC power is supplied to the fixture, and the convertor connector is closed indicating that the emergency inverter battery is charging. After installing, mark with the "PUSH TO TEST" and "CHARGING INDICATOR LIGHT" labels.

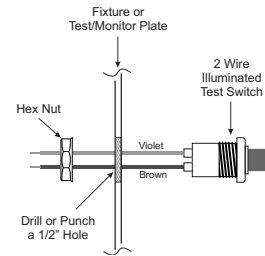

STEP #3 ► WIRING THE EMERGENCY DRIVER

- > Select the appropriate wiring diagram to connect the emergency driver to the AC driver and LED load. Make sure all connections are in accordance with the National Electrical Code and any local regulations.
- > After installation is complete, supply AC power to the emergency driver and join the unit engage connector.
- > At this point, power should be connected to both the AC driver and the emergency driver, and the Charging Indicator Light should illuminate indicating the battery is charging.
- > A short-term discharge test may be conducted after the emergency driver has been charged for one hour. Charge for 24 hours before conducting a long-term discharge test. Refer to OPERATION.
- > In a readily visible location, attach the label **"CAUTION - This Unit Has More Than One Power Connection Point. To Reduce The Risk Of Electric Shock, Disconnect Both The Branch Circuit-Breakers Or Fuses And Emergency Power Supplies Before Servicing."**

OPERATION

Connecting the unit engage connector enables the emergency circuit and supplies power to the control/monitor circuit and charging indicator light. The self-testing emergency driver continually monitors the unit health. Should the unit detect an unusual condition, the indicator light will flash.

When AC power fails, the self-testing emergency driver automatically switches to emergency mode, keeping the LED load illuminated at a reduced lumen output for a minimum of 90 minutes. When AC power is restored, the self-testing emergency driver returns to charging mode.

SELF-TESTING OPERATION

This unit contains a control/monitor circuit that automatically performs a 30-second discharge test once a month and a full 90-minute discharge test once a year. During routine testing, the self-testing emergency driver simulates an AC power failure causing the unit to automatically switch to emergency mode. The unit will monitor the operation of the LED load, battery voltage, LED load connections and emergency duration. If the emergency system functions properly, then the unit will return to normal mode. Should the unit detect any problems, the indicator light will flash per failure condition (see Troubleshooting guide) until the condition has been corrected and the unit passes the next test.

To reset a failure indication, turn off AC power to the emergency driver for a minimum of 10 seconds or briefly push the 2W-ITS. If the condition has not been corrected by the next scheduled test, the unit will once again detect the failure and signal the failure indicator.

To perform a manual self-diagnostic test, push and hold 2W-ITS for minimum of 5 seconds. Once 2W-ITS is released the emergency driver will perform a 30 second diagnostic test. During this test, unit will monitor the operation of the LED load, battery voltage, and LED load connections. If the emergency system functions properly, the unit will return to normal mode. Should the unit detect any problems, the indicator light will flash per failure condition (see Troubleshooting guide) until the condition has been corrected and the unit passes the next test.

TROUBLESHOOTING GUIDE

STATUS INDICATOR LIGHT	PROBLEM	CORRECTIVE ACTION
Light on not flashing	None	None, Unit is Operating Correctly.
Flashing 2 times every 5 seconds	Battery Error	Charge battery. If after an hour failure is still indicated, see action below.
Flashing 3 times every 5 seconds	Charging Error	Ensure input wiring is correct and verify voltage is correct and stable.
Flashing 4 times every 5 seconds	Output Error	<ol style="list-style-type: none"> 1. Output might be either open or short circuited. 2. Ensure that fixture wiring is in accordance with proper wiring diagram. 3. Ensure connections to the LED load.
Continuous Flashing	Application out of range	Ensure LED load is operational and specified for self-testing emergency driver

MAINTENANCE

This self testing emergency driver automatically performs required routine testing. Results are reported to maintenance personnel via the indicator light.

Note: Maintenance personnel should periodically check the indicator light. If the indicator light is flashing, follow steps in the *Troubleshooting Guide*.

Failure Status will be reset when the unit passes:

- The next automatic test, or
- Briefly pressing the 2W-ITS, or
- A power failure exceeding 10 seconds.

NOTE: The unit engage connector pins must be connected for the emergency driver and AC driver to operate normally.

TCASE TEST POINT LOCATION

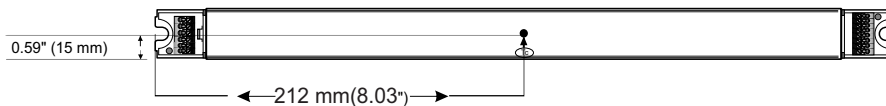

EMERGENCY DRIVER AND AC DRIVER MUST BE FED FROM THE SAME BRANCH CIRCUIT

TYPICAL SCHEMATICS ONLY. MAY BE USED WITH OTHER DRIVERS. CONSULT THE FACTORY FOR OTHER WIRING DIAGRAMS.

WIRING DIAGRAMS

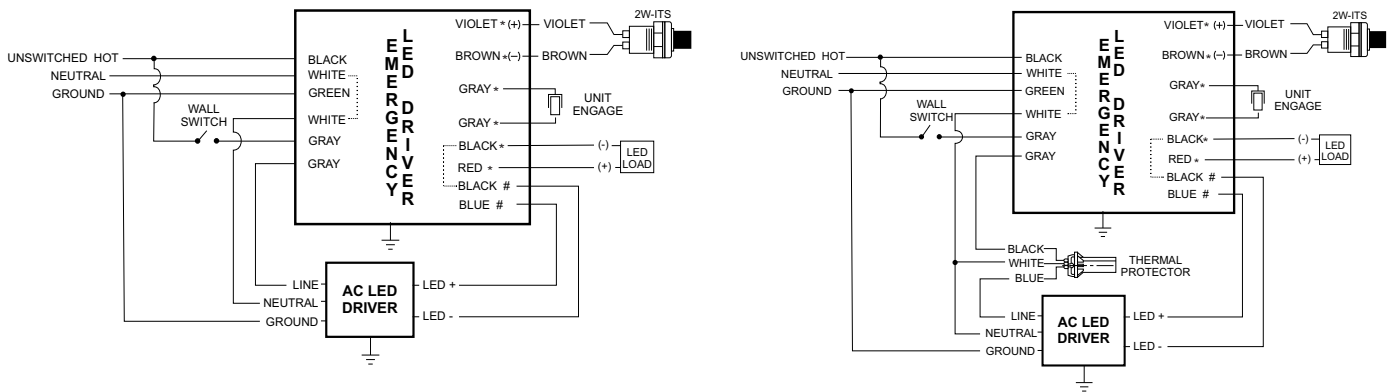

WITH THERMAL PROTECTOR

NOTE 1: For short-term testing of the emergency function, the battery must be charged for at least one hour. The emergency driver must be charged for at least 24 hours before conducting a long-term test.

NOTE 2: Connections with * are Class 2 rated outputs.
Connections with # are Class 2 rated inputs only.