



Advance Xitanium linear LED drivers with SimpleSet technology are designed to give OEMs ultimate flexibility. With wide operating windows, slim profile and simple programming, the drivers enable luminaire manufacturers to design luminaires of different sizes and lumen levels for office and retail applications.

Specifications

Input Voltage (Vac)	Output Power (W)	Output Voltage (V)	Output Current (A)	Efficiency@ 35.7V and 70°C Case (%)	Max. Case Temp. (°C)	Input Current (A)	Max. Input Power (W)	THD @ Max. Load (%)	Power Factor @ Max. Load	Surge Protection (Ring Wave, KV)	Envir. Protection Rating	Driver Type
120	75	27 – 54 Class 2 Output	0.1 -2.0	86	Life-80°C UL-90°C	0.75	89	<10%	>0.95	2.5	UL damp & dry	Constant Current
277				88		0.3		<15%				

Enclosure

	In. (mm)
Case Length	16.69 (424)
Case Width	1.18 (30)
Case Height	1.00 (25.4)
Mounting Length	16.34 (415)

Wiring Diagram

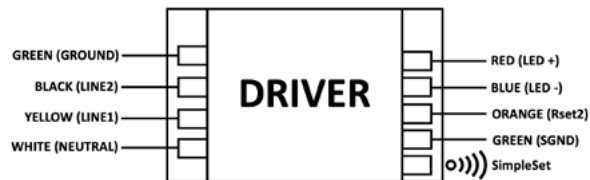

Note: Line 1 & Line 2 need to be connected to the same phase.

Warning

Install in accordance with national and local electrical codes.
Use 18AWG solid copper wire.
Rated $\geq 300V/90^{\circ}C$.
Strip wire 3/8".

The field-wiring leads or push-in terminals shall be fully enclosed.

Grounding

Driver case must be grounded.

Dimming	Dimming Range (with specified dimmers)	Minimum Output Current (A)	Other Comments
Step Dimming	10-70% 100%	0.07	

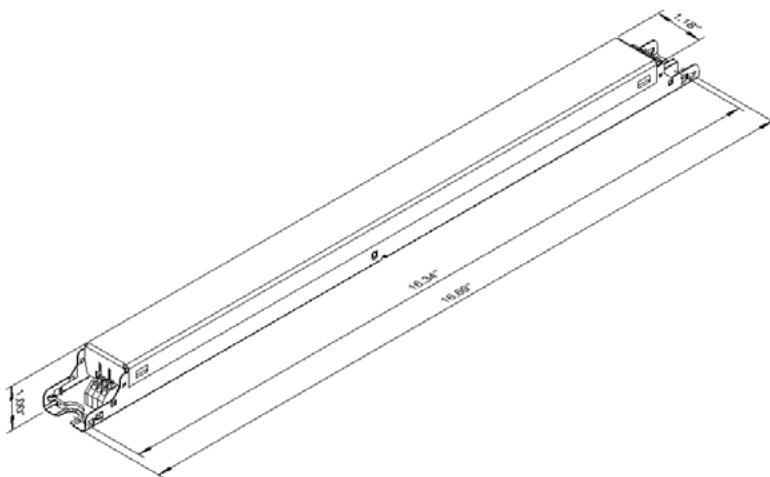

Xitanium XI075C200V054SST1

75W 0.1–2.0A 54V Step Dimming INT with SimpleSet

Features

- 50,000+ hour lifetime¹
- SimpleSet programmable
- Large operating window
- Step minimum dim level

Benefits

- Slim profile housing enables easy design-in with excellent thermal performance
- Enables simple, fast, flexible application-specific configurations
- Enables fixture designs with comprehensive application coverage for various loads and lumen levels

Application

- Indoor linear applications such as troffers and pendants
- Office
- Education
- Healthcare
- Retail

Electrical Specifications

All the specifications are typical and at 25°C Tcase unless specified otherwise.

Product Data

Order Information	
Full Product Code	XI075C200V054SST1M (Mid-Pack, 12pcs/Box), 12NC: 929000789113
Line Frequency	50/60Hz
Min. Mains Voltage Operational	108 Vac
Max. Mains Voltage Operational	305 Vac
Output Information	
Maximum Open Circuit Voltage	< 60Vdc, Class 2 output
Output Current Ripple (ripple = peak to average / average)	15% max. @ max. Iout 4% max. @ visible for stroboscopic frequency range 60Hz–3KHz
Output Current Tolerance (in the performance window)	<5%
Protections	Short Circuit, Open Circuit Protection for LED + and LED – and Temperature Foldback
Features	
Step Dimming	Step dimming (tri-level or bi-level, refer to step dimming table)
AOC (adjustable output current)	100mA to 2000mA via external resistor or SimpleSet programming (default set to 2000mA, refer to graph)
Additional SimpleSet Configurable Features	Adjustable minimum dimming level, Dimming mode selection (bi-level or tri-level), Adjustable output level, Adjustable output min., OEM write protection
Environment & Approbation	
Operating Ambient Temp. Range	–20°C to +50°C
Max. Case Temperature (Tcase)	85°C
Agency Approbations	UL8750, UL1310, cUL, Class P (UL, cUL)
Electromagnetic Compliance	FCC Title 47 Part 15 Class A
Audible Noise	<24dB Class A
Weight	0.9 Lbs/0.41 kgs

1. Advance Xitanium LED drivers are manufactured to engineering standards correlating to a designed and average life expectancy of 50,000 hours of operation at maximum rated case temperature. Minimum 90% survivals based on MTBF modeling.

Xitanium XI075C200V054SST1

75W 0.1–2.0A 54V Step Dimming INT with SimpleSet

Electrical Specifications

All the specifications are typical and at 25°C Tcase unless specified otherwise.

Step Dimming

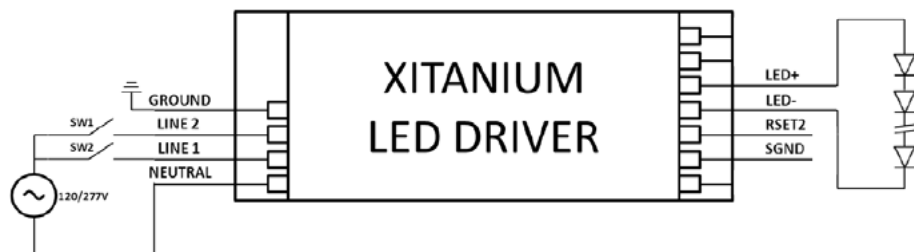

		Output Current			
		Bi_level		Tri_level (Default)	
SW1	SW2	Config Range	Default	Config Range	Default
Open	Close	10%-70%	40%	10%-70%	30%
Close	Open	10%-70%	40%	10%-70%	70%
Close	Close	100%	100%	100%	100%
Open	Open	0%	0%	0%	0%

Xitanium XI075C200V054SST1

75W 0.1-2.0A 54V Step Dimming INT with SimpleSet

Electrical Specifications

All the specifications are typical and at 25°C Tcase unless specified otherwise.

AOC (Adjustable Output Current) Settings (Rset)

Rset (Ohms)	Current (mA)	Rset (Ohms)	Current (mA)
0	100	3800	1072
10	100	4000	1099
50	100	4200	1129
80	100	4400	1154
90	100	4600	1181
100	100	4800	1206
110	105	5000	1227
120	111	5200	1249
130	116	5600	1293
140	119	6000	1331
150	125	6400	1367
160	130	6800	1402
170	133	7200	1432
180	138	7600	1462
190	141	8000	1490
200	146	8400	1517
250	168	8800	1541
300	190	9200	1563
350	212	9600	1585
400	231	10000	1604
450	253	10500	1629
500	272	11000	1653
550	291	11500	1672
600	310	12000	1694
650	329	12500	1713
700	348	13000	1730
750	368	13500	1746
800	384	14000	1763
850	400	14500	1776
900	419	15000	1793
950	436	15500	1806
1000	452	16000	1817
1100	485	16500	1831
1200	515	17000	1842
1300	545	17500	1853
1400	575	18000	1864
1500	602	18500	1874
1600	632	19000	1885
1700	657	19500	1894
1800	684	20000	1902
1900	709	20500	1913
2000	733	21000	1921
2100	755	21500	1929

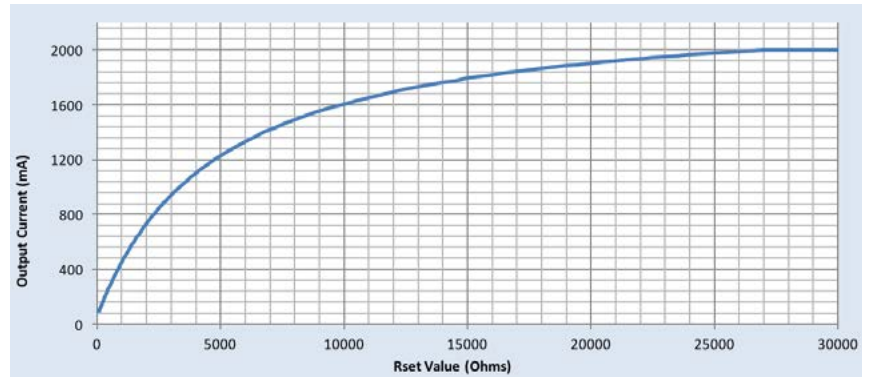

Notes

1. Current is set via a resistor between Rset2 and SGND leads.
2. Any through-hole or SMD resistor with >0.25W and >20V can be used as Rset.
3. Driver will default to 2000mA when Rset is left open.

Rset	Current	Rset	Current
2200	780	22000	1934
2300	802	22500	1943
2400	823	23000	1951
2500	843	23500	1956
2600	864	24000	1965
2700	883	24500	1970
2800	903	25000	1975
2900	922	25500	1984
3000	941	26000	1989
3200	976	26500	1995
3400	1009	27000	2000
3600	1042	30000	2000
		>100,000	2000

Xitanium XI075C200V054SST1

75W 0.1–2.0A 54V Step Dimming INT with SimpleSet

Electrical Specifications

All the specifications are typical and at 25°C Tcase unless specified otherwise.

Driver Output Window

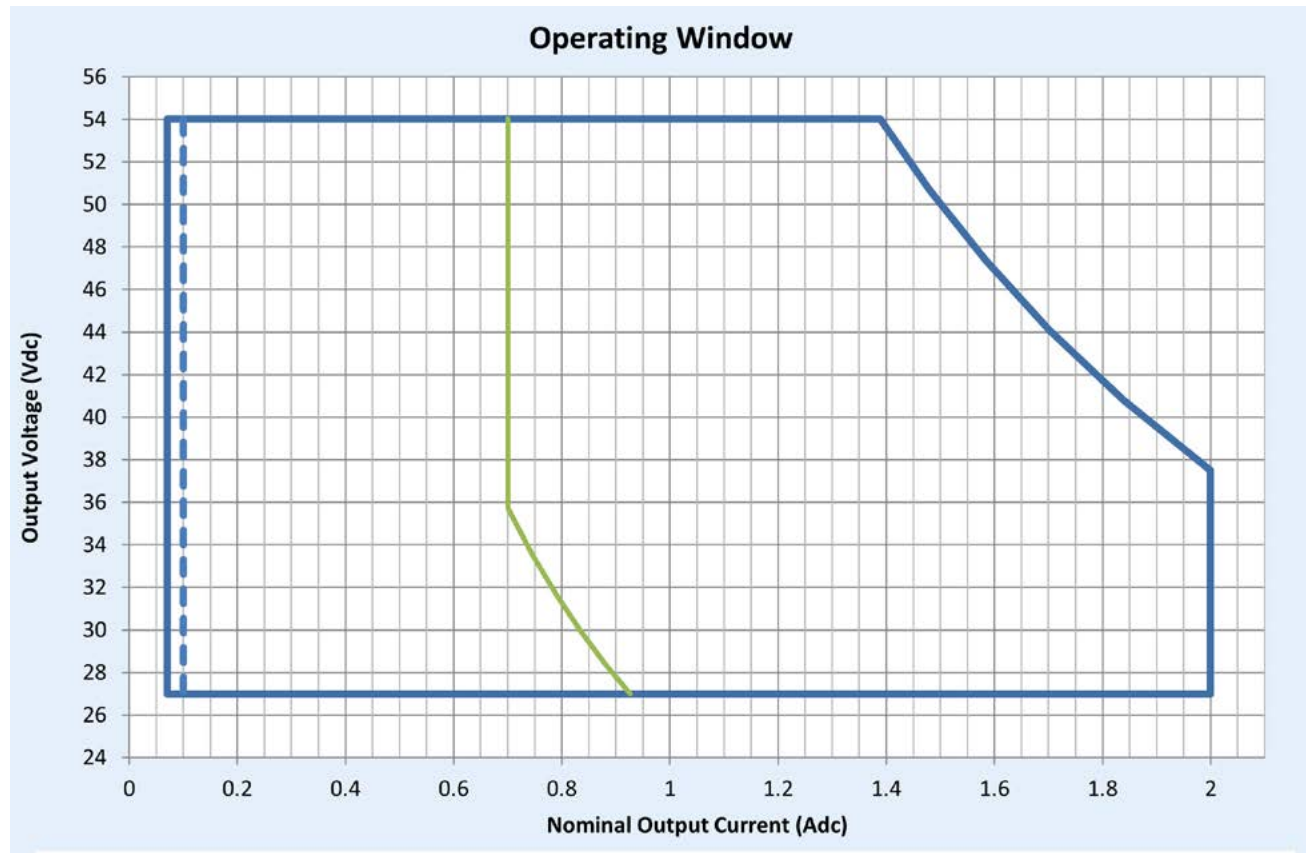

Notes

1. Factory default output current is 2A.
2. For dimming to a minimum level of 10% the output current setting through AOC should be $\geq 0.7A$.

Xitanium XI075C200V054SST1

75W 0.1–2.0A 54V Step Dimming INT with SimpleSet

Electrical Specifications

All the specifications are typical and at 25°C Tcase unless specified otherwise.

Output Current Vs. Driver Case Temperature

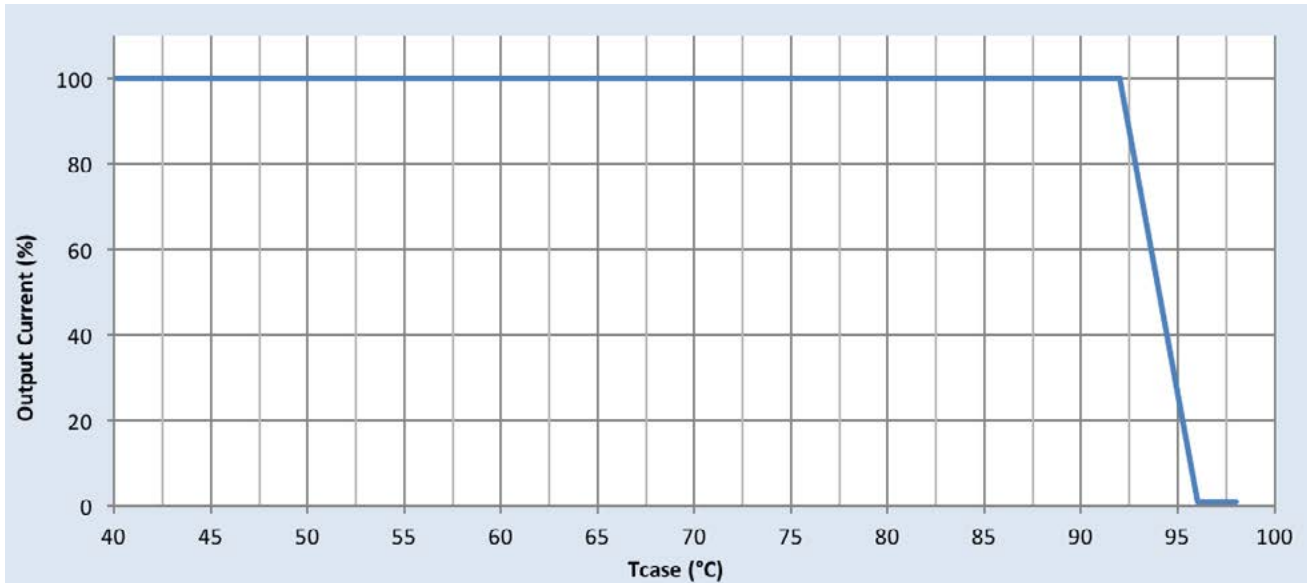

Note: There is $\pm 5^\circ\text{C}$ tolerance on the driver case temperature.

Driver Lifetime Vs. Driver Case Temperature

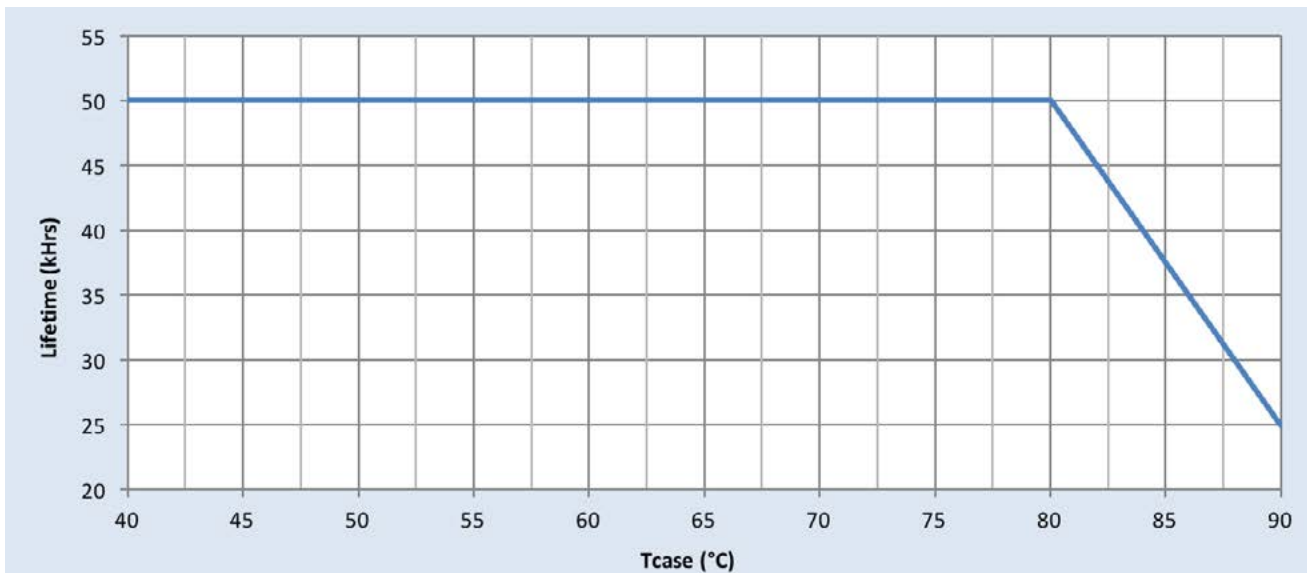

Xitanium XI075C200V054SST1

75W 0.1-2.0A 54V Step Dimming INT with SimpleSet

Performance Characteristics

Based on measurements on a typical sample at 75°C T case. The accuracy of the measurements is within the tolerance of the measurement instruments.

Efficiency Vs. Output Power at 120Vac

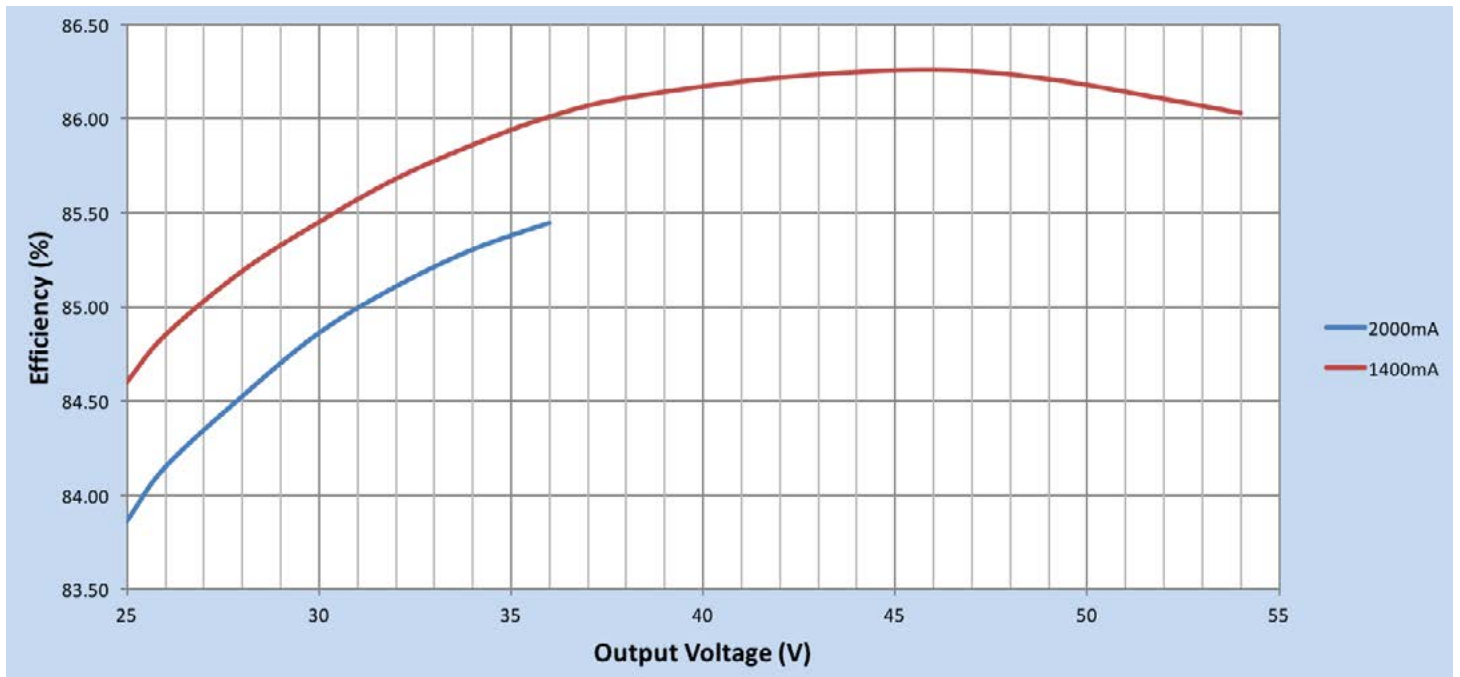

Efficiency Vs. Output Voltage at 277Vac

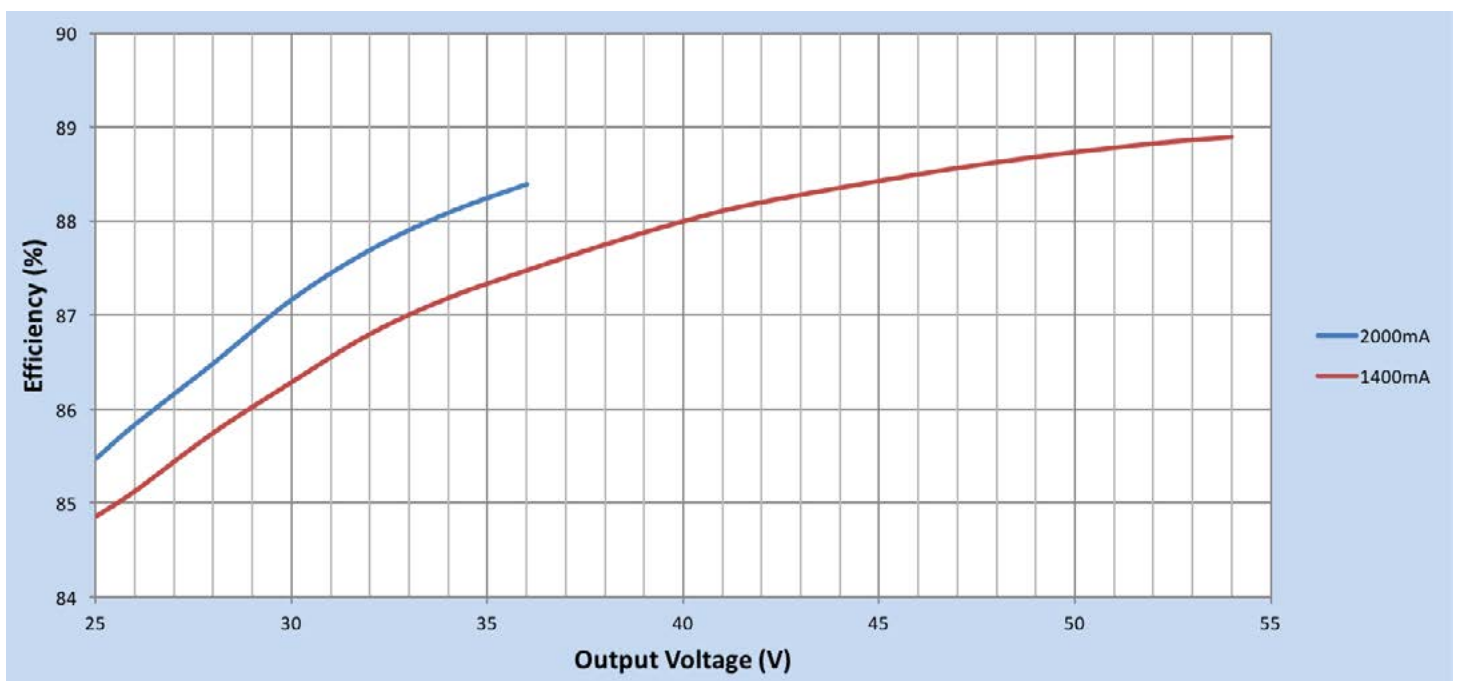

Xitanium XI075C200V054SST1

75W 0.1-2.0A 54V Step Dimming INT with SimpleSet

Performance Characteristics

Based on measurements on a typical sample at 75°C T case. The accuracy of the measurements is within the tolerance of the measurement instruments.

Power Factor Vs. Output Power

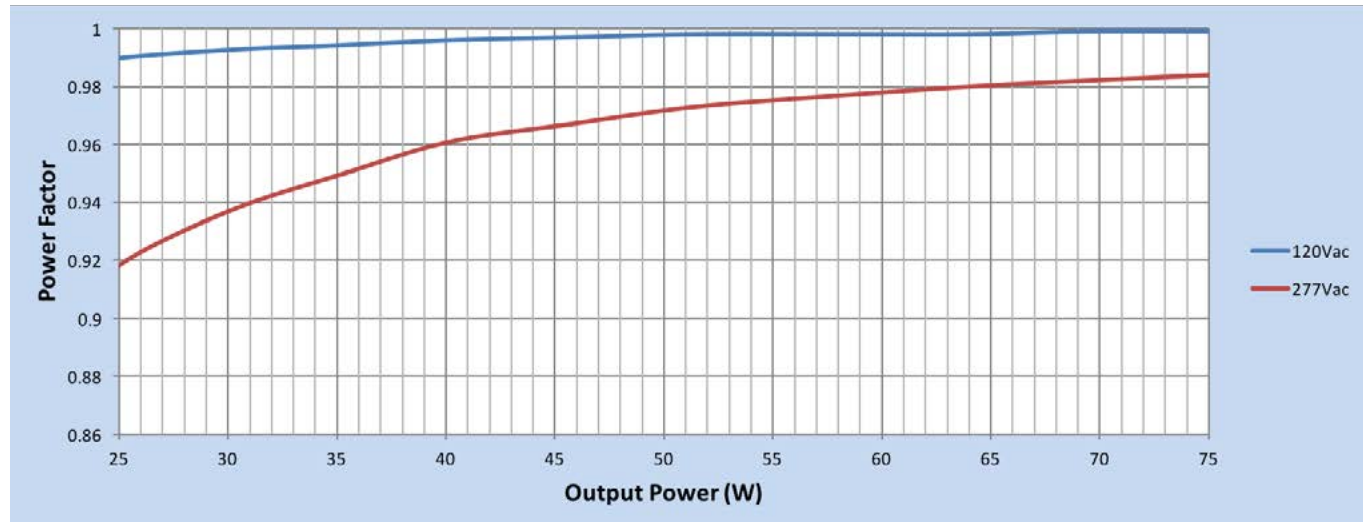

Total Harmonic Distortion (THD) Vs. Output Power

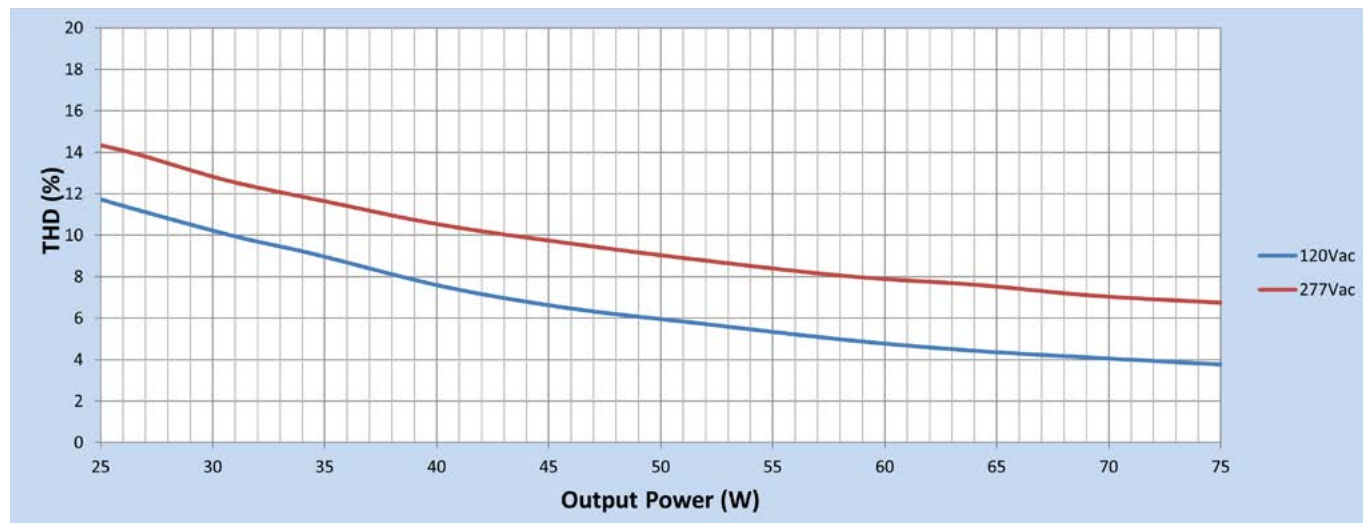

Xitanium XI075C200V054SST1

75W 0.1–2.0A 54V Step Dimming INT with SimpleSet

Inrush Current Info

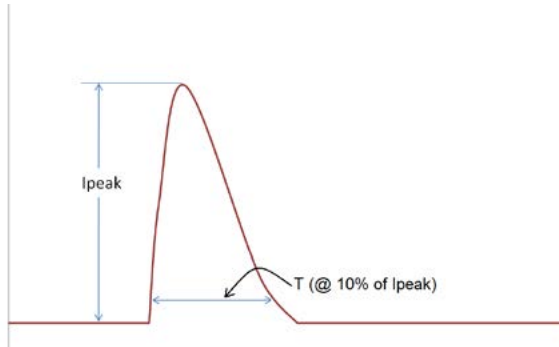

V_{in}	I_{peak}	T (@ 10% of I_{peak})
120 Vrms	19A	360 μ S
277 Vrms	48A	370 μ S

Inrush current is measured at peak of the corresponding line voltage. Source impedance per NEMA 410.

Lightning Surge Info

ANSI Surge Type	Differential Mode (L-N)	Common Mode (L-G, N-G, L&N-G)
100kHz Ring Wave (w/t 30 Ω)	2.5KV	2.5KV

Isolation

Isolation	Input	Output	0-10V	Enclosure
Input	-	2xU+1kV	2.5kV	2xU+1kV
Output	2xU+1kV	-	2.5kV	500V
Enclosure	2xU+1kV	500V	500V	-

U = Max. input voltage



© 2022 Signify Holding. All rights reserved. The information provided herein is subject to change, without notice. Signify does not give any representation or warranty as to the accuracy or completeness of the information included herein and shall not be liable for any action in reliance thereon. The information presented in this document is not intended as any commercial offer and does not form part of any quotation or contract, unless otherwise agreed by Signify.

Signify North America Corporation
400 Crossing Blvd, Suite 600
Bridgewater, NJ 08807
Telephone: 855-486-2216

Signify Canada Ltd.
281 Hillmount Road,
Markham, ON, Canada L6C 2S3
Telephone: 800-668-9008

All trademarks are owned by Signify Holding or their respective owners.