

# BSL718

## Installation Instructions

CLASS 2 OUTPUT

EMERGENCY LED DRIVER

# bodine



### **! IMPORTANT SAFEGUARDS !**

**WHEN USING ELECTRICAL EQUIPMENT, BASIC SAFETY PRECAUTIONS SHOULD ALWAYS BE FOLLOWED, INCLUDING THE FOLLOWING:**

### **READ AND FOLLOW ALL SAFETY INSTRUCTIONS**

**WARNING:** Risk of personal injury or property damage - Certain models of this emergency LED driver contain sealed lead-acid (SLA) battery. When these models are installed in a sealed and gasketed luminaire it must incorporate a proper venting method. See page 3 for additional battery application notes.

1. Do not join converter connector until installation is complete. If AC voltage is supplied to the unit with the converter connector open, the 2W - ITS will blink 3 times every 5 seconds. This indicates either the battery is disconnected or the converter connector is open.
2. This product is for use with an emergency LED lighting load and supplies up to 18.0 W of power (measured at nominal battery voltage) with a maximum rated current of 900 mA and a maximum voltage of 50 VDC in emergency mode for a minimum of 90 minutes.
3. Make sure all connections are in accordance with the National Electrical Code or Canadian Electrical Code and any local regulations.
4. To reduce the risk of electric shock, disconnect both normal and emergency power supplies and converter connector of the emergency driver before servicing.
5. This emergency driver is suitable for both factory or field installation. For field installation, please see the instructions on page 2.
6. This product is suitable for use in damp locations with ambient temperature range of either -20°C to +60°C or 0°C to +60°C (see label for your specific temperature range). Product is not suitable for heated air outlets and wet or hazardous locations. Maximum allowable case temp is 80°C. See Product Unit Label for measurement location.
7. An unswitched AC power source is required (120-277 VAC, 50/60 Hz).
8. Do not install near gas or electric heaters.
9. The battery is field replaceable. Contact manufacturer for information on replacement. Use caution when replacing battery. Dispose of the battery properly. Do not incinerate.
10. The use of accessory equipment not recommended by the manufacturer may cause an unsafe condition.
11. Do not use this product for other than intended use.
12. Servicing should be performed by qualified service personnel.
13. Equipment should be mounted in locations and at heights where it will not be subjected to tampering by unauthorized personnel.
14. For Canadian application the output terminals should be in compliance with the accessibility requirement of the Canadian Electric Code.
15. This device complies with part 15 of the FCC Rules. Operation is subject to the following two conditions: (1) this device may not cause harmful interference, and (2) this device must accept any interference that may cause undesired operation.
16. This product must be grounded. See the wiring diagrams for details.

## **SAVE THESE INSTRUCTIONS**



**THIS PRODUCT CONTAINS A RECHARGEABLE BATTERY.  
THE BATTERY MUST BE RECYCLED OR DISPOSED OF PROPERLY.**

02/25/19

Bodine © 2018 Signify Holding. All rights reserved.

236 Mt. Pleasant Rd. • Collierville, TN USA 38017-2752 • Tech Support 888-263-4638 • Fax 901-853-5009 • www.bodine.com  
81000163

# INSTALLATION



**CAUTION: DO NOT JOIN CONVERTER CONNECTOR UNTIL INSTALLATION IS COMPLETE AND AC POWER IS SUPPLIED TO THE EMERGENCY DRIVER.**

**NOTE:** Make sure the necessary branch circuit wiring is available. An unswitched source of power is required. The emergency driver must be fed from the same branch circuit as the AC driver.

This product is suitable for field installation with suitable LED loads including LED luminaires, DC voltage driven LED replacements for fluorescent lamps and others. There are four (4) checks to determine if your luminaire is eligible for field installation.

1. Ensure the LED load's rated power is greater than or equal to the power output of this emergency LED driver. This is to ensure that this emergency product will not produce more power than the LED load can handle, thus ensuring that the LED load will not be damaged when the system is in the emergency mode.
2. Verify that the forward voltage of the luminaire's LED array is within the limits of this emergency LED driver. The forward voltage of the LED array is commonly designated as Vf and should be found on the luminaire markings, in the luminaire specifications, or imprinted directly on the LED arrays. If multiple LED arrays are to be driven, verify that the total forward voltage is within the limits of this product. Using a voltage meter, it may be possible to directly measure the voltage across the LED arrays when operating from the AC driver.
3. Ensure the output current of the LED driver does not exceed 5.0 Amps. This is the current into the blue wire.
4. Ensure there will be sufficient light output in the end application. Estimate the egress lighting illumination levels by doing the following:
  - a. Find the efficacy of the LED load. This can be provided by the luminaire manufacture. This number will be given in lumens per watt (lm/w). It is the installer's responsibility to validate the luminaire manufacturer's efficacy data. This can be accomplished by direct measurement, by review of independent 3rd party test data (UL, ETL, etc.), accessing a public database of 3rd party data (such as Design Lights Consortium, [www.designlights.org](http://www.designlights.org)), or other comparable means.
  - b. Lumens can be calculated by multiplying the output power of the emergency LED driver by the efficacy of the LED load. In many cases the actual lumen output in emergency mode will be greater than this calculation gives, however it will provide a good estimate for beginning the lighting design of the system.
  - c. Using the results of this calculation and industry standard lighting design tools, calculate the anticipated illumination levels in the path of egress.

***Lumens In Emergency Mode = Lumens per Watt of Fixture \* Output Power of Chosen Product***

$$\underline{\hspace{2cm}} \text{ (Lumens) } = \underline{\hspace{2cm}} \text{ (lm/W) } * \underline{\hspace{1cm}} \text{ 18 (W) }$$

**NOTE:** This product has been designed to reliably interface with a wide selection of LED loads and is electrically compatible with every simple LED array that meets criteria 1 and 2 above. However, compatibility cannot be guaranteed with all current and future LED systems. Compatibility testing of the end-use system is suggested. Please contact the factory with any questions.

**NOTE:** After installation, it will be necessary to measure the egress lighting illumination levels to ensure it complies with national, state, and local code requirements.

**Installation of this emergency LED driver will vary based on the luminaire type, however, generally follow these steps:**

## STEP #1 INSTALLING THE EMERGENCY DRIVER

- > Disconnect AC power from the LED luminaire.
- > Mount the emergency LED driver by the mounting tabs using the supplied screws. The luminaire's installation instructions may provide guidance on the recommended mounting location.
- > The emergency LED driver may be remote mounted from the luminaire. If used in conjunction with an AC driver, this distance is up to half the distance the AC driver manufacturer recommends remote mounting the AC driver from the LED Load. If used without an AC driver, the emergency LED driver can be remote mounted at distances up to those given in Table 1.
- > **Mounting Height:** This product meets or exceeds the NFPA minimum light requirements with all loads, down to the smallest rated lamp load, at heights up to 7.17ft (2.2m). Many factors influence emergency illumination levels, such as the lamp load selected, luminaire design, and environmental factors therefore end use verification is necessary. For field installations, when the attached luminaire is mounted at heights greater than 7.17ft (2.2m), the level of illumination must be measured in the end application to ensure the requirements of NFPA 101 and local codes are satisfied.

## STEP #2 INSTALLING THE BATTERIES



- WARNING:**
- > The battery must be wired using the provided connection wires. Refer to the Wiring Diagrams section for connections.
  - > Never charge or discharge a SLA battery in a hermetically sealed enclosure. Batteries generate a mixture of gases internally. Given the right set of circumstances, such as extreme overcharging or shorting of the battery, these gases might vent into the enclosure and create the potential for an explosion when ignited by a spark.
  - > Do not place batteries in close proximity to objects which can produce sparks or flames.

# INSTALLATION

> Do not install SLA batteries upside down (see Illustration 1).

**ILLUSTRATION 1**

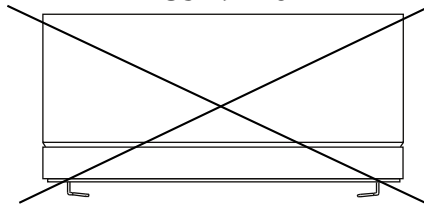

## STEP #3 INSTALLING A TEST SWITCH

> Refer to Illustration 2 and 3 to install a typical low voltage illuminated test switch.

**ILLUSTRATION 2**

**Illuminated 2W-IPTS Test Switch**

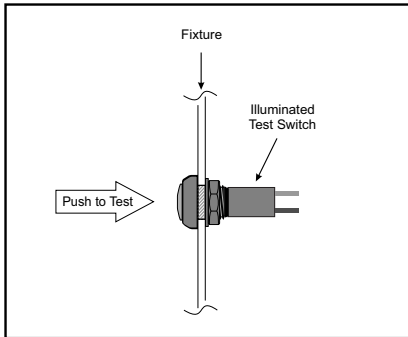

**ILLUSTRATION 3**

**Illuminated 2W-IPTS Test Switch**

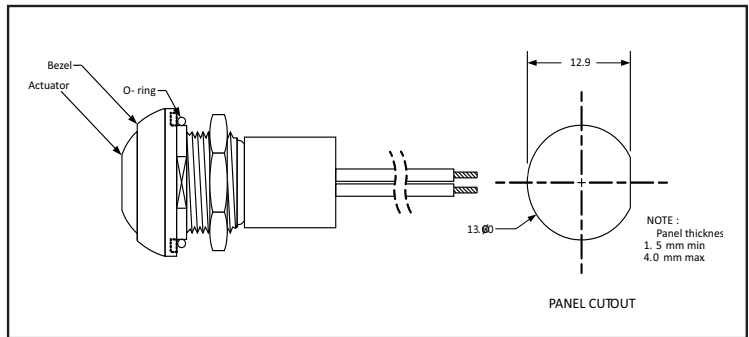

## STEP #4 WIRING THE EMERGENCY DRIVER

- > Make sure all connections are in accordance with the National Electrical Code and any local regulations. Refer to the wiring diagrams section for connections.
- > After installation is complete, supply AC power to the emergency driver and join the converter connector.
- > At this point, power should be connected to both the AC driver and the emergency driver, and the Charging Indicator Light should illuminate indicating the battery is charging.
- > A short-term discharge test may be conducted after the emergency driver has been charged for one hour. Charge for 24 hours before conducting a long-term discharge test. Refer to OPERATION.
- > In a readily visible location, attach the label **"CAUTION - This Unit Has More Than One Power Connection Point. To Reduce The Risk Of Electric Shock, Disconnect Both The Branch Circuit-Breakers Or Fuses And Emergency Power Supplies Before Servicing."**

## OPERATION

During normal operation AC power is applied, the charging indicator light is illuminated, indicating that the battery is being charged. When power fails, the emergency LED driver automatically switches to emergency power operating the LED load for a minimum of 90 minutes. When AC power is restored, the emergency driver returns to the charging mode.

## MAINTENANCE

### Testing:

Although no routine maintenance is required to keep the emergency driver functional, it should be checked periodically to ensure that it is working. The following schedule is recommended:

1. Visually inspect the charging indicator light monthly. It should be illuminated.
2. Test the emergency operation of the fixture at 30-day intervals for a minimum of 30 seconds. The LED load should operate at reduced illumination.
3. Conduct a 90-minute discharge test once a year. The LED load should operate at reduced illumination for at least 90 minutes.

**! REFER ANY SERVICING INDICATED BY THESE CHECKS TO QUALIFIED PERSONNEL !**

## Battery Replacement Procedure

**WARNING:** Always use the same quality and type of battery as replacements

Substituting batteries not supplied by Bodine will void the UL listing of the system and may cause equipment failure. To ensure the superior performance of your system and to maintain proper charger operation, replace depleted batteries only with Bodine batteries having the same part number, voltage and ampere-hour rating as the original batteries. Install new batteries per the wiring diagrams.

**EMERGENCY DRIVER AND AC DRIVER MUST BE FED FROM THE SAME BRANCH CIRCUIT**  
TYPICAL SCHEMATICS ONLY. MAY BE USED WITH OTHER DRIVERS. CONSULT THE FACTORY FOR OTHER WIRING DIAGRAM.

## WIRING DIAGRAMS

### Ni-MH or Ni-Cd Battery Installation

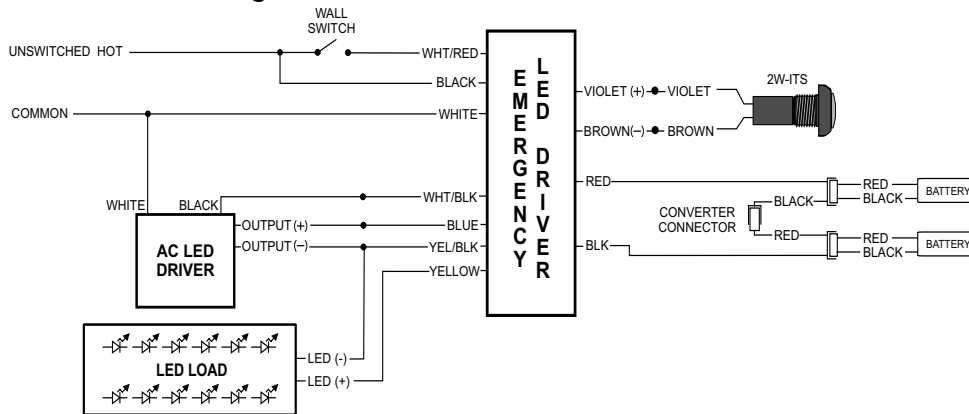

### SLA Battery Installation Single Battery Option

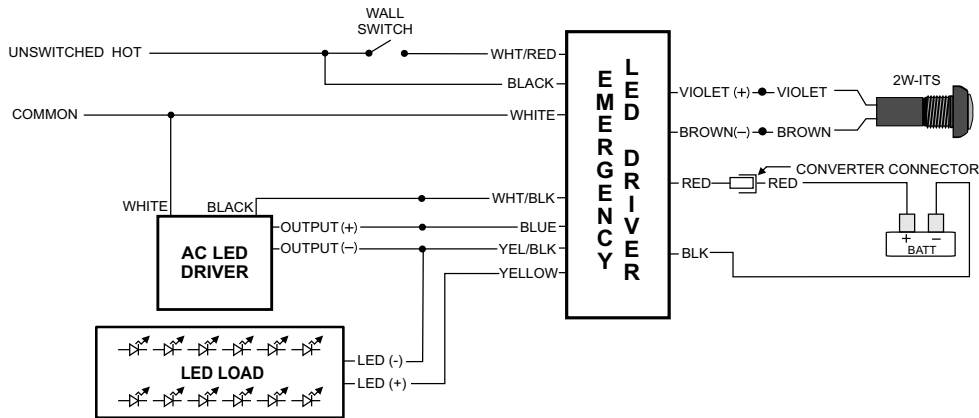

### SLA Battery Installation Two Battery Option

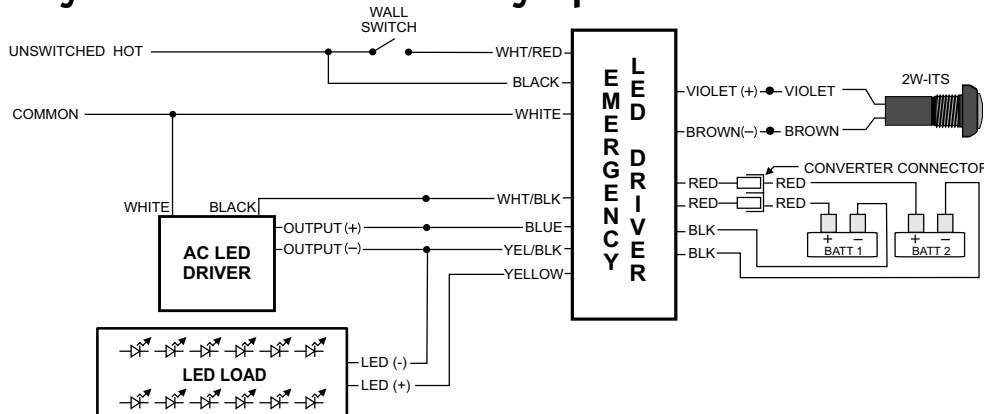

**NOTE:** For short-term testing of the emergency function, the battery must be charged for at least one hour. The emergency driver must be charged for at least 24 hours before conducting a long-term test.